

ΕΛΑΣΤΡΟΝ ΑΕΒΕ

MINERAL WOOL PANELS

ASSEMBLY/ HANDLING/LOADING INSTRUCTIONS



MINERAL WOOL PANELS

Assembly Instructions

Important safety notice

The panels should always be installed by an experienced team using all the adequate equipment. The panels should not be installed during snow and rain falls or during a dense fog. The panel assembly works should be stopped when the visibility reduces at dusk, and there is no artificial lighting provided. Sealing operations should be performed in the ambient temperature above 4°C.

Protective Film

The external facings of panels are protected with protective film from dirt and damage. The film is applied during the panel production process. Remove the film while installing the panel, however no later than 3 weeks from purchasing sandwich panels. If panels are stored for a longer period of time, the foil should be removed at the latest after the expiry of 3 weeks. If panels are stored in the open air, they should be protected against the sun. Otherwise removing of the film may be difficult. After short-term exposure to weather conditions, the film starts to crack, which in turn may make its removal from panel external cladding difficult. Peel the protective film off the longitudinal edges of panels prior to commencement of assembly. Remove protective film from internal cladding of panels, where such elements as flanges, dome skylights or waterdrains are installed. No peeled film can be left on the panel after the assembly. The film, when left, might lead to varnish staining due to penetration of water and might also interrupt the designed water drainage.

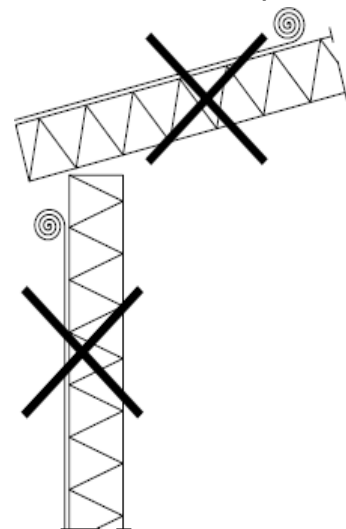

Health and Safety considerations

All works related to the assembly of sandwich panels, have to be carried out in keeping with the applicable occupational health and safety regulations, for the assembly and roofing works, following the local laws and regulations, under supervision of authorized staff. In addition, use the following fall restraint equipment during panel assembly:

- rope barriers to secure near by buildings.
- lifelines and safety belts of assembler.

Preparing for Assembly

Before you attempt to install sandwich panels proceed as follows: Check the structure for compliance with design specifications and construction accuracy. Make sure the spacing of purlins, columns and spandrel beams is consistent with the original design. Make sure the purlins surfaces form a plane. Verify the alignment of column spandrels of the wall structure. Prepare necessary tools for assembly of panels. Proper structure preparation will facilitate the assembly, and result in faultless performance of fasteners and joints, ensuring aesthetical building finish. No welding is allowed in the proximity of panels as this might permanently damage the panel coat.

Cutting panels and flashings on site

It is recommended to cut sandwich panels with sawing machines having fine-toothed blades, or with circular saws (see fig. 1), provided that they are fitted with accurate guiding systems. Remove burrs and other steel swarf immediately after cutting.

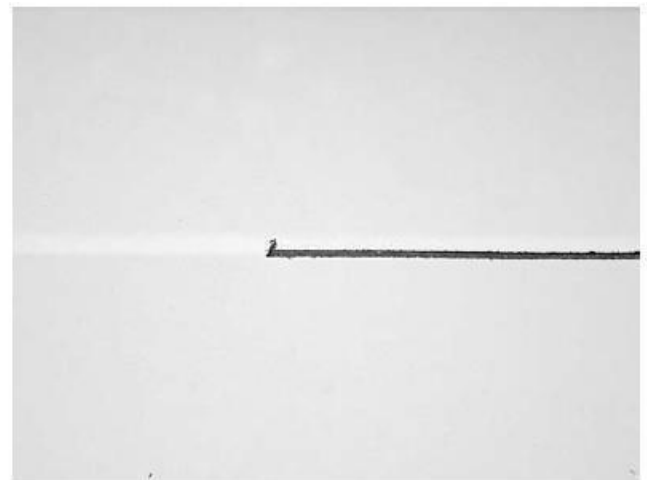

Fig. 1. Adequate equipment for cutting panels.

No angle grinders, and any other machines that might cause overheating within the cutting zone – and consequently damage the corrosion protection – are allowed for cutting panels and flashings. (see fig. 2)



Fig. 2. Inappropriate tool for cutting panels.

Openings cut in roof and wall components, before the panel is assembled, weaken its cross - sectional structure, therefore adequate stiffening should be provided in those places. In order to protect the surface from damage cut the panels and flashings on special stands lined with soft fabric such as felt etc. Remove the protective film, if any, from the flashings, before their assembling. It is prohibited to cut the panels on roof, work platforms, scaffolding etc.

Fasteners for panel assembly

Use manufacturer recommended self-drilling fasteners for fixing sandwich panels. The fastener type will depend upon the load carrying structure and the thickness of panel being assembled. In order to achieve adequate fastening of the panel to the structure, it is essential to maintain perpendicular fastener position while fixing, therefore the use of special screw guns fitted with heads for long fasteners is highly recommended. Use stainless steel fasteners for fixing panels to structures where the following conditions are present:

- inside the building there is a permanent moisture content of above 70%,
- chemically aggressive atmosphere is present inside,
- the equipment stored requires particular protection.

For wall panels exposed to direct sunlight (main source of temperature stress) the screw holes must be predrilled with a 2mm larger diameter hole in order to avoid cross-sectional loads that cause buckling deformations.

In end supports the distance of the screw from the panel edge should be $\geq 70\text{mm}$ while for intermediate support the spacing of the screws apart should be $\geq 40\text{mm}$

Thanks to special design support fasteners with no thread in the area under fastener head and a washer with EPDM layer, watertight and durable fastening is achieved in one operation, which eliminates clearance between the sandwich panel and its base. For the correct fixation please see fig. 3.

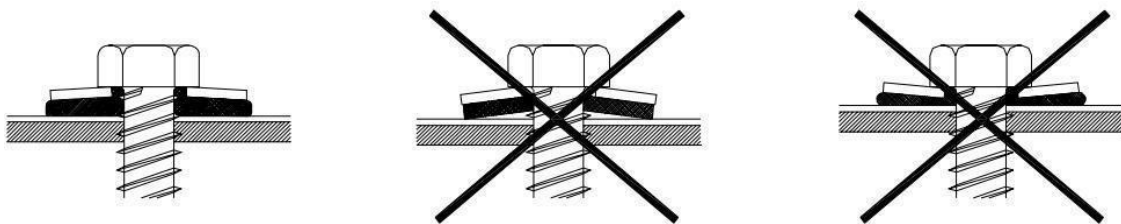
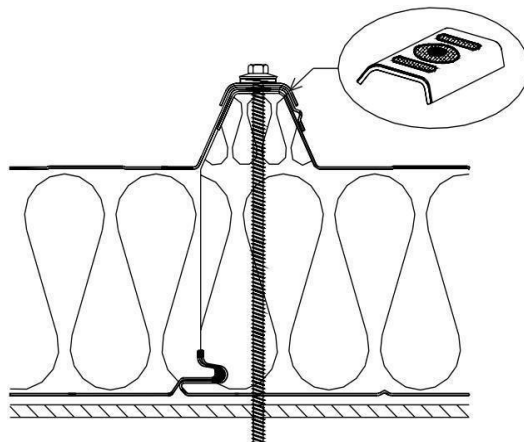

Fig. 3. Correct fixation of the self-drilling fasteners

Especially roof panels are fixed through the trapezoidal sections (caps) by means of mandatory use of saddle washers with seals (see fig. 4). The trapezoidal sections are of the same RAL color.



Taking panels from package

The use of a crane is the most convenient method for panel assembly on the roof. Panels must be lifted one-by-one from the package, using appropriate commercially available tools, such as clamps with felt or rubber lined metal pads. Lift the mineral wool core panel, to stand on its side edge first, to allow attachment of appropriate channel bar holder, and then lift it to the upright position following the below instructions.

1. First lift the top panel sideways for approx. 200mm. Do not ever drag the panels on the package, there is a serious possibility of scratching the surfaces.

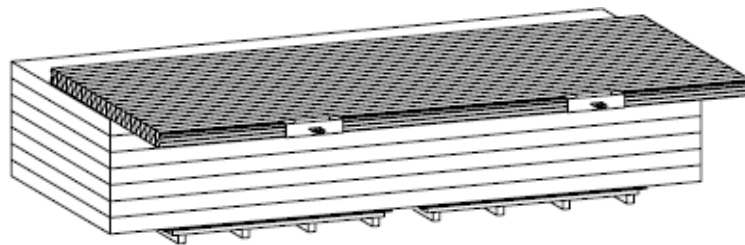

2. As a second step, put distancers under the top panel in order to avoid damage to the lower piece.

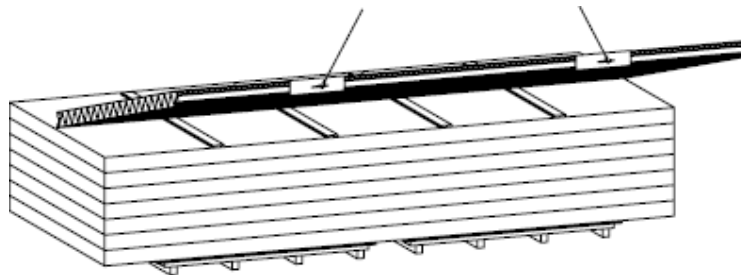

3. Lift the panel on its longer edge on the distancers.

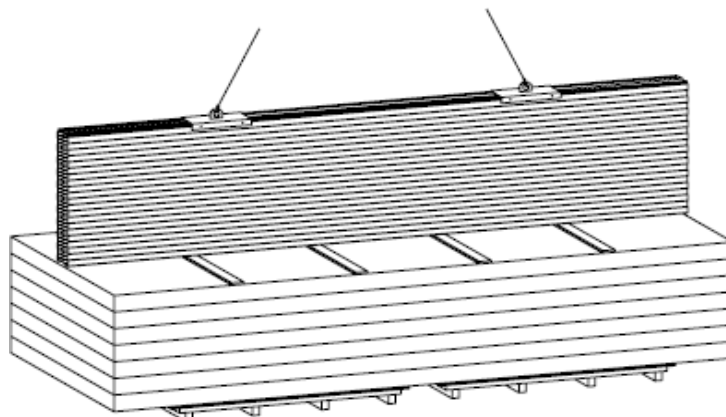

4 . If the panel is to be installed vertically an appropriate rotating device should be used, as shown in the below figures.

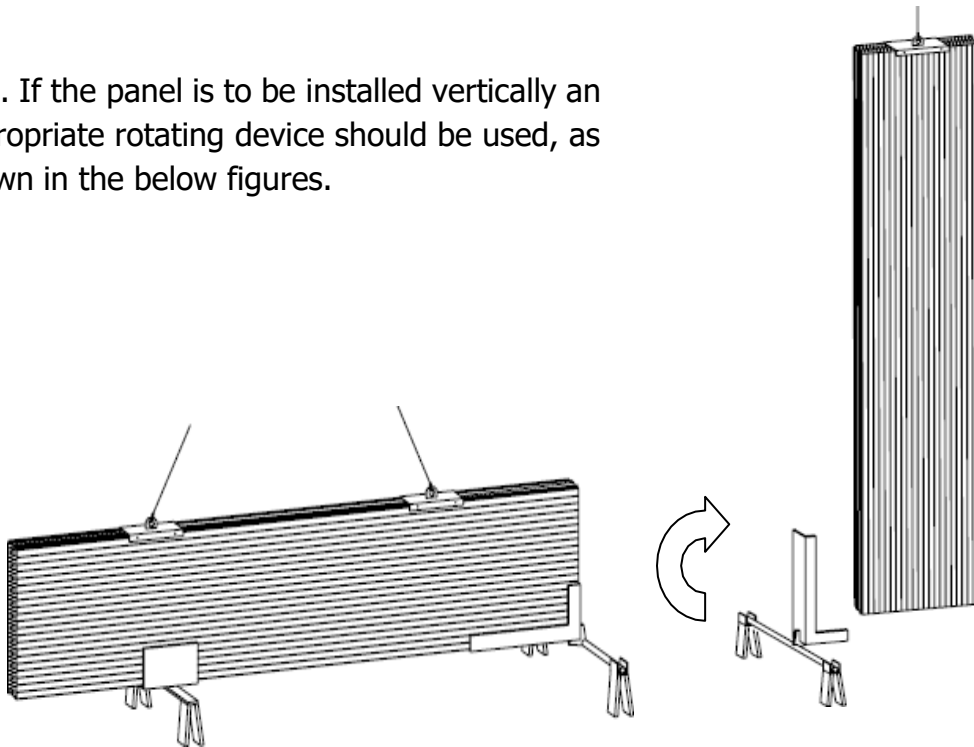

According to our long experience, the most common reasons for performance defects reported for structures are the following:

- applying solutions other than recommended by the sandwich panel manufacturer's information,
- replacing the manufacturer-recommended materials with others,
- failure to utilize professional equipment,
- untrained workers fixing the panels.

Assembling roof panels

The following minimum inclination of roof made of sandwich panels is required:

2. > 5 % for roofs of continuous panels, without transverse joining and skylights.
3. > 7 % for roofs of joined panels or with skylights.

Minimum width for roof supports

Always check the support for compliance with design specifications. Make sure the purlins surfaces form a plane. The minimum support width is 60mm (see fig. 5), unless in area of overlapping where a minimum of 100mm is required.

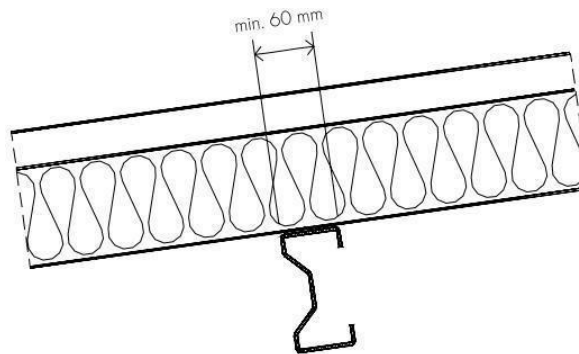

Fig. 5. Minimum width for roof supports.

A dripping edge of at least 80 mm should be made on panels in the eaves to prevent moistening mineral wool in the panel (see fig. 6). Cleanliness of these edges is to be checked on-site; if required the rests of wool and adhesive are to be removed.

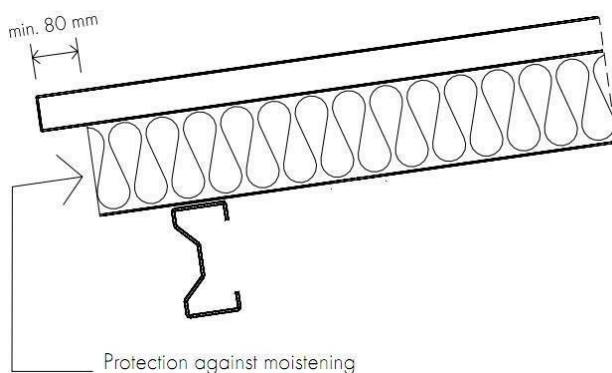

Fig. 6. Dripping edge.

Lifting and installation of the panels

Roof panels can be assembled either with vacuum lifter (recommended) or with mechanical gripper. When assembling roof panels which are longer than 12 m, use cross beams. Use a piece of section: I-bar or channel bar as a holder to attach the panel in several points along the cross beam (every 3-4 m). While assembling the panels with the use of a lift, bear in mind the roof inclination, otherwise the panel edges might get damaged.

Remove the protection film from the inside panel facing before placing it onto the roof structure. Soft shoes (in order not to damage panel coating) should be worn by the workers while installing the roof panels. Merge each subsequent panel with the previous one by putting the trapezoid-shaped flash of the top panel cladding onto the ridge of the adjoining panel (see fig. 8 and 8a).

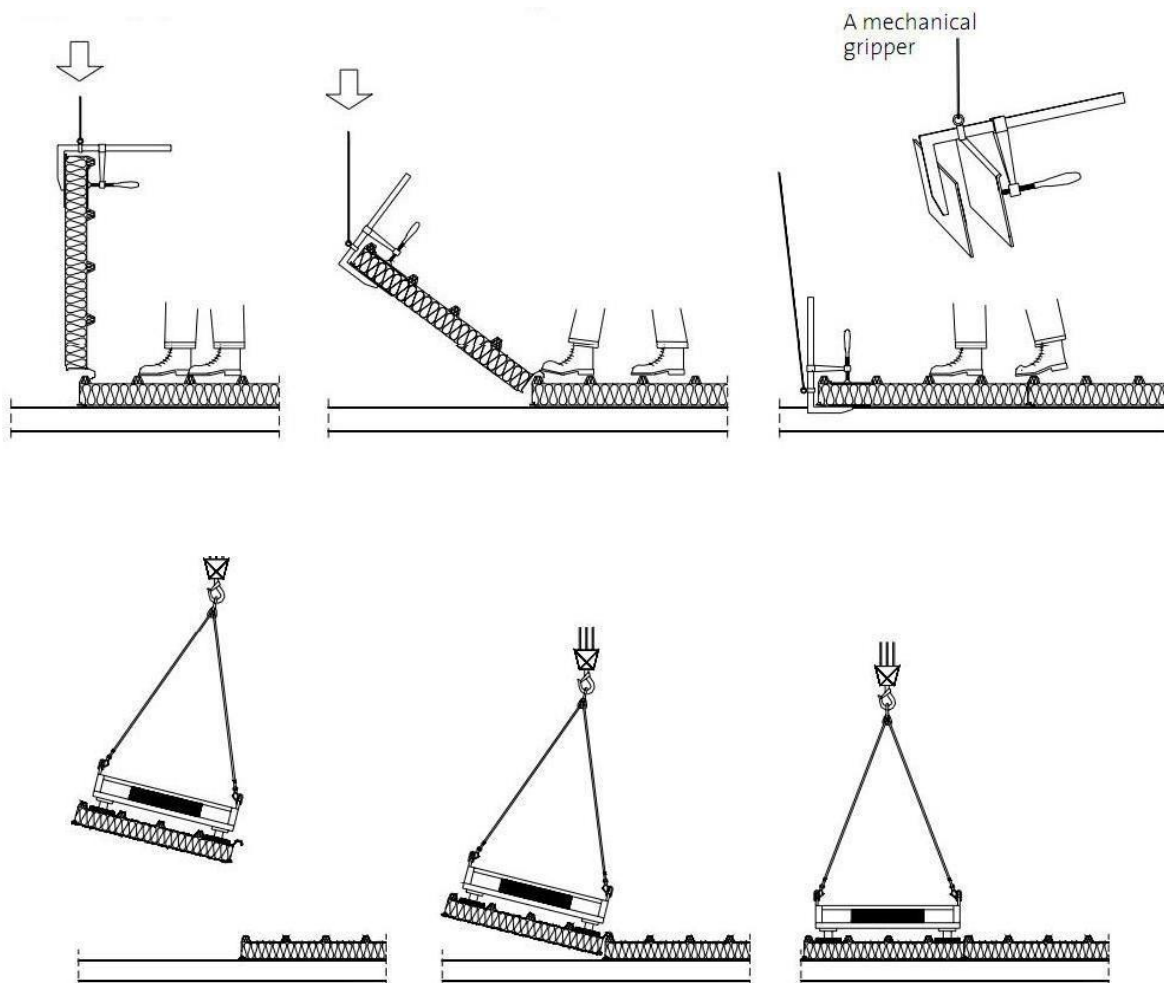

Fig. 8. Assembly of panels using mechanical grippers.

Fig. 8a. Assembly of panels using vacuum lifter.

While joining roof panels, apply butyl sealing compound in the scarf joint groove, to eliminate the risk of air and moisture penetration. Correct facing between roof panels is presented in fig. 9. The lengthwise displacement should be reduced to minimum, to protect the sealants.

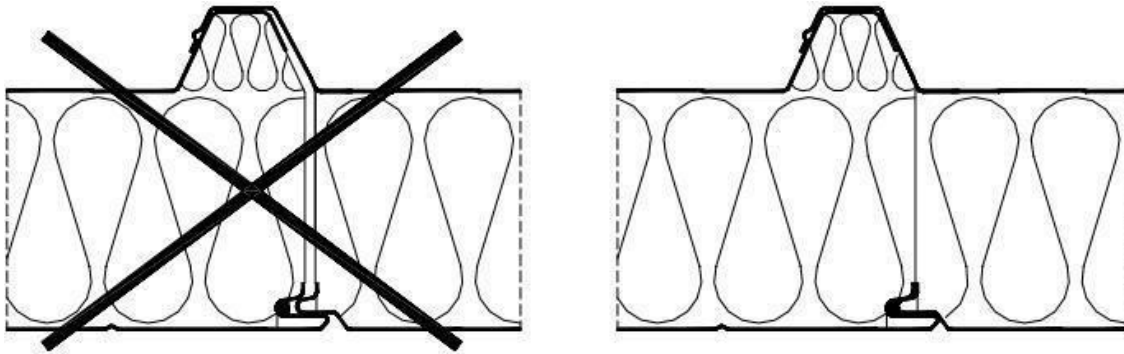

Fig. 9. Roof panels tight joint.

Roof extension

In case of buildings with slopes longer than 12 - 15m where roof panels is not possible to be transported in one piece, longitudinal extension of panels is required by overlapping of at least 200mm (see fig. 10). In that case it is very important to keep always the correct assembly sequence (see fig. 11).

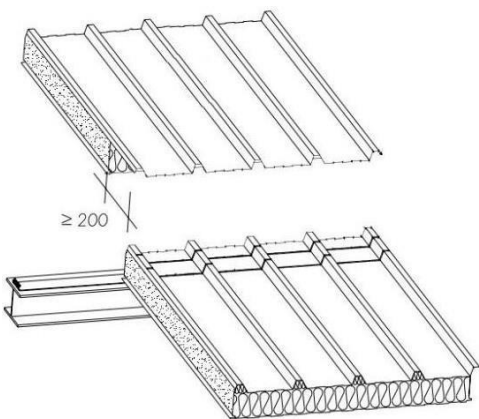

Fig. 10. Roof panels overlapping ≥ 200 mm.

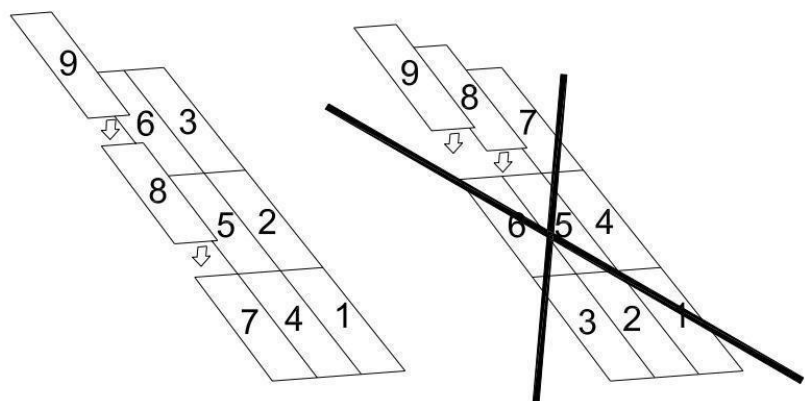

Fig. 11. Correct assembly sequence

Assembling wall panels

Wall panels can be assembled either with vacuum lifter (recommended) or with mechanical means. The following instructions refer mainly in the case of lack of vacuum lifter which would make the installation procedure faster, safer and more accurate. The use of a lift is the most convenient method for assembly of wall panels. Prepare lifting sling of appropriate length, matched to that of the panel and wall height.

Wall panels can be lifted directly from the package (refer to instructions in pag.5) with the use of a clamp, depending on the installation orientation (vertical or horizontal) lined with soft material such as felt or rubber in the inside. The clamp width must be matched to the panel thickness (see fig. 12).

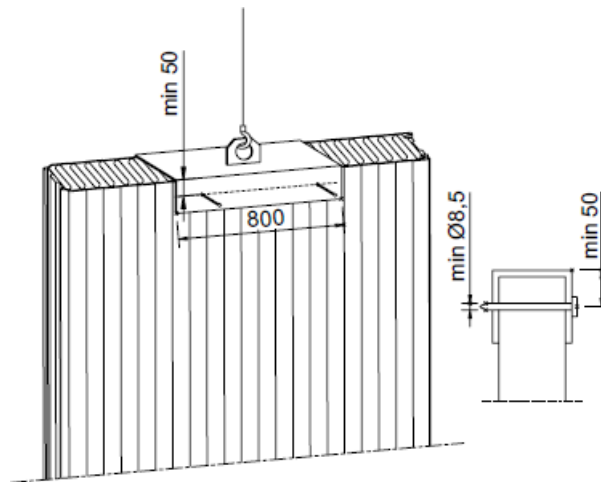

Fig. 12. Typical clamp for vertical assembly.

Wall panels can be also assembled in horizontal orientation using adequate clamps (see fig. 13). Special care should be given to avoid damaging the evident facing of the panels.

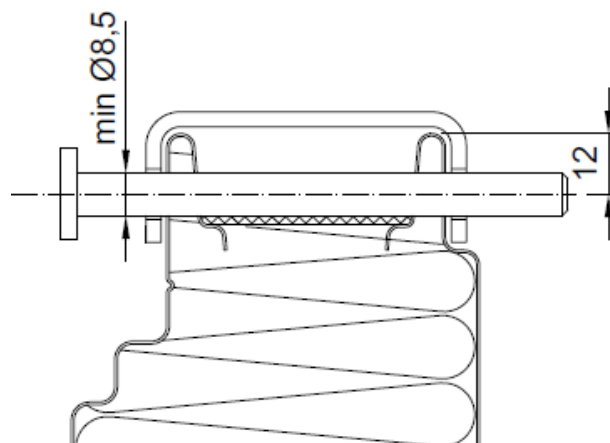

Fig. 13. Typical clamp for horizontal assembly.

Begin the installation of the first panel with the tongue facing in the direction of installation. Lift the panel in place with the lifting tool. Always follow the instructions for use and the safety instructions of the panel lifting thoroughly before starting installation. Insulating wool must be installed in the bottom edge to ensure the tightness and thermal insulation of the external wall (see fig 14).

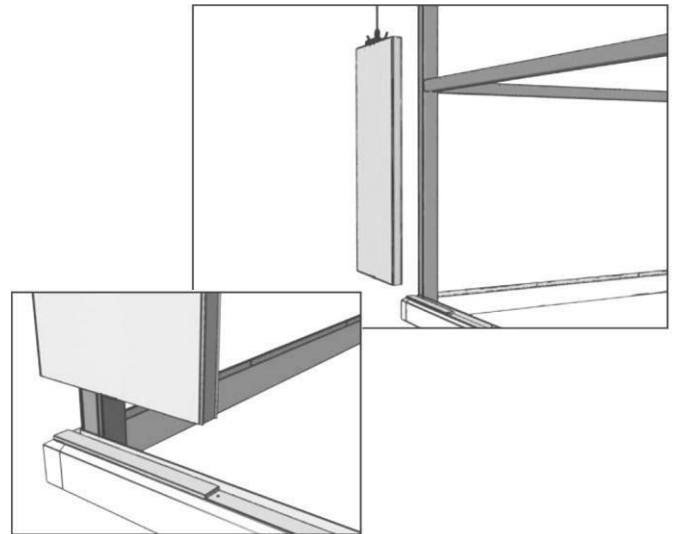

Fig. 14. Insulation wool in the bottom edge.

In cases of taller buildings and if a second row of wall panels has to be installed, an overlapping of the exterior sheet should be implemented just like the roof extension described above with a minimum of overlapping of 50mm. Substructure should always be adequate in order to bear loadings of the above rows. NEVER allow wall panels to be supported on top of the lower installed panel without any loadbearing construction elements such as steel angles or thick galvanized flashings.

On sites where there is not enough space to store packages close to the installation point and panels must be transported and assembled manually. Panels must always be lifted to it's longer edge and forwarded to the installation point only one piece at a time using at least two employs depending on the panel length and weight (see fig. 14).

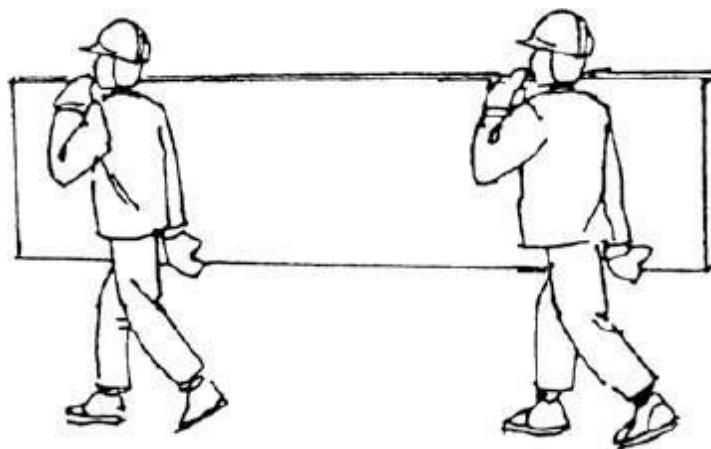

Fig. 14. Manual transportation of panels.

In order to place each panel on the correct position when assembling manually and to achieve a tight fixation the procedure of the below figure 15 should be followed.

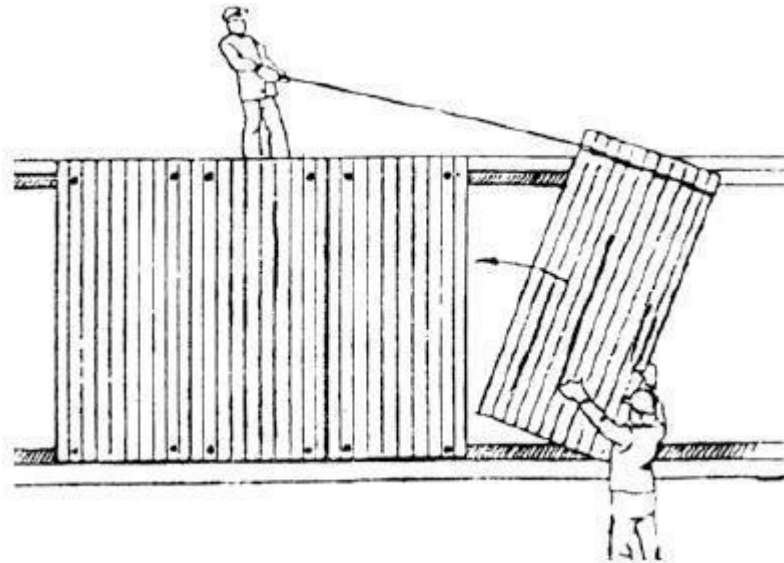

Fig. 15. Manual installation of panels.

While lifting long panels for vertical arrangement from the package, secure the lifting to avoid damaging edges of the panel lifted and panels remaining in the package. Lift the panels for horizontal arrangement using the adequate clamp depending on the panel's length (see fig. 16 - 17).

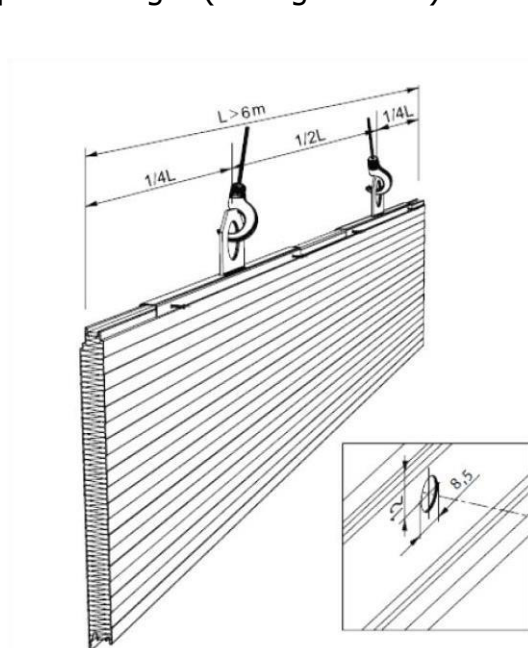

Fig. 16. Clamp application $L > 6m$.

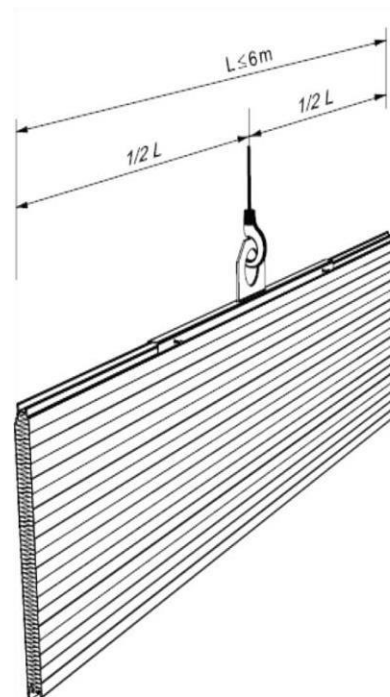
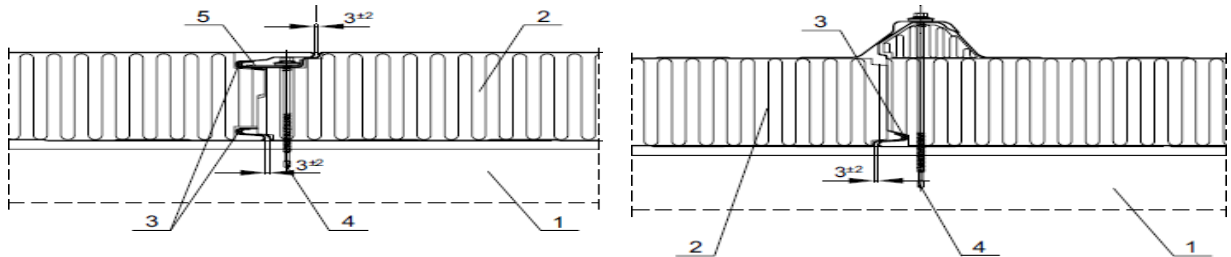

Fig. 17. Clamp application $L \leq 6m$.

Correct assembly of the panels should result in a tight fixation between consecutive panels with a gap of 3 ± 2 mm in the steel joint. Extra care should be taken to avoid the damage of the surface by overtightening the self-drilling fasteners (see fig.18-19). Fire resistant silicate sealant should always be applied in joints to achieve both airtightness and fire resistance properties.

Furthermore, the joints of panels are stitched by steel self-drilling screws spaced each 300mm on both panel sides.



1 - Steel substructure 2 - Mineral wool panel 3 - silicate sealant 4 - self-drilling fastener

Fig. 18. Secret fix joint.

Fig. 17. Roof joint.

Cleaning and Maintenance

After completion of assembly:

Removing the protective film, manually remove all dirt, grease and dust, with water solution of mild cleaning agent, using cotton cloth or sponge. Next, rinse the surface with fresh water. Cleaning should be done in temperatures above zero.

Good practice requires that at least annually, a service check of the facade and the whole building must be performed. The purpose of this is to remove any possible failures and increase the life span of the panels. The annual check includes:

Annual service check:

Removal of all dirt on the façade and washing the facade if necessary. We recommend that you wash the facade annually with a soft brush. If necessary, a mild cleaning agent can be added. Wash the facade from top to bottom with running water.

General maintenance advice:

Do not use aggressive cleaning agents to clean the facade in order to prevent damage to corrosion protection. Do not use a grinder near panels, as the hot particles will damage the paint. In case of any questions regarding maintenance or damage repair, consult.