

Thermal insulated polyurethane panels

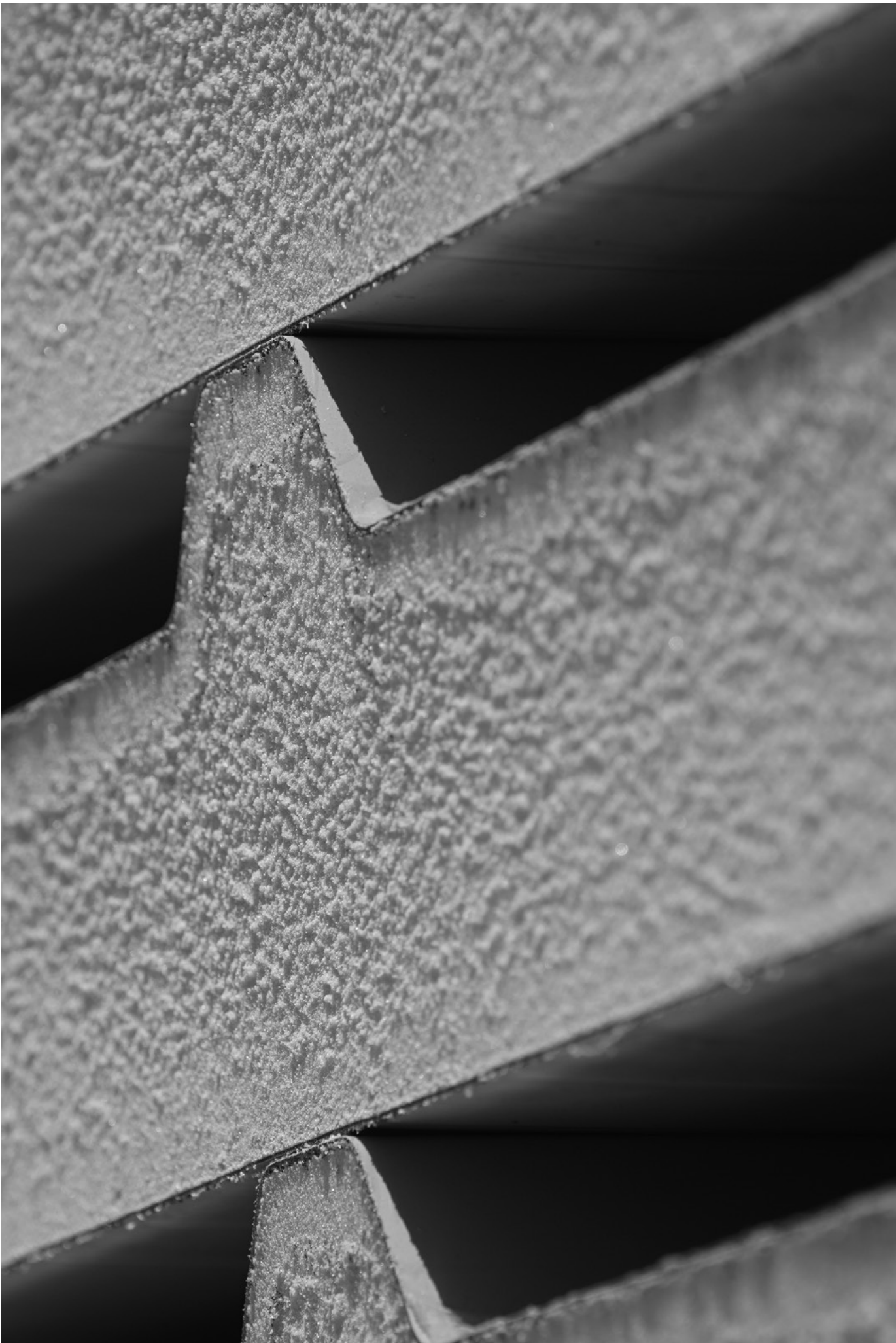



Contents



Introduction	5
Basic principles	6
Description	6
ECOPANEL® RL (roof panel)	7
ECOPANEL® WLC (wall panel - concealed fix)	8
ECOPANEL® WL/FW (wall panel - internal partition - visible fix)	9
ECOPANEL® FL (cold room panel)	10
AGROPANEL RL (roof panel)	11
EASYPANEL®	11
Table of options for all cladding solutions	12
Technical specifications	12
Metal sheets options / colours	13
RAL Colour chart	13
Final coating (paint) steel sheets qualities	14



Introduction



The CORE products of ELASTRON S.A. are distinguished and well-known for the reliability of the composite thermal insulated polyurethane panels, used for commercial buildings and others.

We focus on three basic points:

- Production of competitive and high-quality products.
- Full technical support at panning and installation stages.
- On time and safe product delivery.

The elements that differentiate the material quality and service provided by our company are:

- The new and technologically innovative mechanical production equipment.
- Strict raw material specifications.
- The swelling of the insulating material through environmentally friendly systems (CFC Free & HCFC Free). Our company was the first that applied the special pentane technology as a swelling material in GREECE.
- The design of our products according to the modern technical market demands.
- Provision of all necessary technical support and consulting at all product stages and on-site workshops installation.
- Co-ordinated custom-made production and distribution of products at project site.

The variety of the Company's products includes:

- Insulated roof panels ECOPANEL® - EASY PANEL® type RL.
- Insulated wall panels ECOPANEL® - EASY PANEL® type WL/FW - WLC.
- Insulated cold room panels ECOPANEL® type FL.
- Insulated roof panels for agricultural facilities type RL.
- Special parts for fitting and finishing (ridges, gutters, water troughs, fronts, etc.)

In addition, we can provide a full range of supporting auxiliary materials that contribute to the perfect functional and aesthetic filling of any type of building (self-drilling screws, adhesive sealants, roof lights, floor ventilations etc.)

The technical consultant's department of the Company will always be at your disposal for any additional information or sample materials that may be requested.

Basic principles



Based on our many years of experience in the construction industry we focus on three main areas:

A. Production and distribution of quality advanced products:

- The basic equipment of the industrial unit consists of two fully automated continuous production lines covering all European requirements for the production of thermal insulated panels.
- The design of thermal insulated panels is based on specialized technicians, aiming at the best aesthetics and functional harmonization with the European standards.
- Selection of raw materials with criteria harmonized with the production of quality advanced products.
- Compliance of the production process to the requirements of the European standards ISO 9001, ISO 14001, ISO 45001, and ISO 50001 as well as to the requirements of the European standard EN 14509 and the CE marking.

B. Improving services and product distribution in the market:

- Creation of a flexible mechanism for the on time and proper materials distribution at the client's premises.

Description

The thermal insulated panel is a product which is produced when two metal sheets are heat-sealed with insulating foam core and create a composite product which is at the same time light and solid, succeeding in combining the maximum advantages of the materials used, meaning strength, insulation, and aesthetics.

In the today's market the name "panel" has prevailed for composite curtain that it first appeared in the structural European market in the '60s. The automation of the production process helped the product to become economically affordable in relation with any other kind of insulation – cladding solution and to conquer the European structural map.

The main advantages of the panels are:

- Thermally reliable.
- Monolithic material industrially produced.
- Long term weather, thermal and structural durability.
- Easy to install.
- Light self-weight of cladding that affects the metal frame.

- Provision of a complete range of supporting auxiliary materials for functional and aesthetic filling of any type of building (flashings, self-drilling screws, adhesive sealants, roof lights, floor ventilations etc.).
- Promotion and execution of each order based on a guaranteed time schedule.

C. Full technical support in all stages of the study, design and implementation of the materials.

- Direct co-operation of Company's executives with design offices and expert scientists during the studying and designing phase in order to cover any technical demands.
- Provision of catalogues that include the technical characteristics of the products and the application capabilities.
- Technical support of application workshops either through installation manuals or through site visits.

- Non-dangerous for human health.
- Without condensation problems.
- Easy to choose colours for the exterior and the interior surface.

Our products combine the above advantages but at the same time it is an economical solution for the cladding of building facilities.

It is also important to harmonize our production process according to the new demands of the global market of foam insulation and construction materials.

The maturation of the foam of the thermal insulation panel does not require environmentally harmful swelling materials such as fluorocarbons and hydrogen chlorofluorocarbons which deplete the atmosphere ozone.

The production process of the panels is CFC Free & HCFC Free as it is called in international terminology.

ECOPANEL® RL (roof panel)



Special technical characteristics

- 1 Broad valley for the easier handling during mounting.
- 2 Large bending radius for avoiding coating cracks.
- 3 Factory-fitted polyurethane foam tape in the female side of overlap for a greater jointing airtightness.
- 4 Special configuration of the inner table of the overlap to ensure waterproofing in cases of heavy rainfall.
- 5 Valley at the top of the trapezoidal to facilitate the fastening of the panels.
- 6 Side aluminum tape to prevent gases from escaping from the polyurethane cells during the maturation of the foam, resulting in better thermal insulation behavior of the panel over time.
- 7 Environmentally friendly and non-ozone depleting CFC Free & HCFC Free foam.

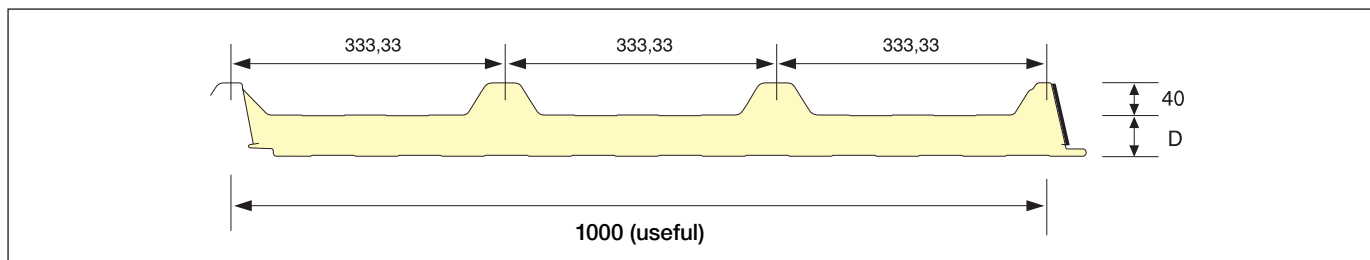
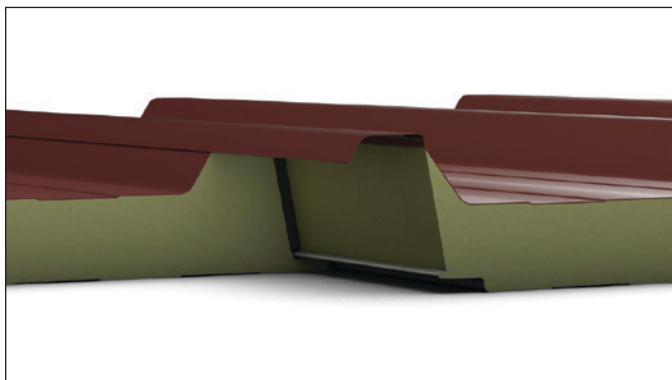
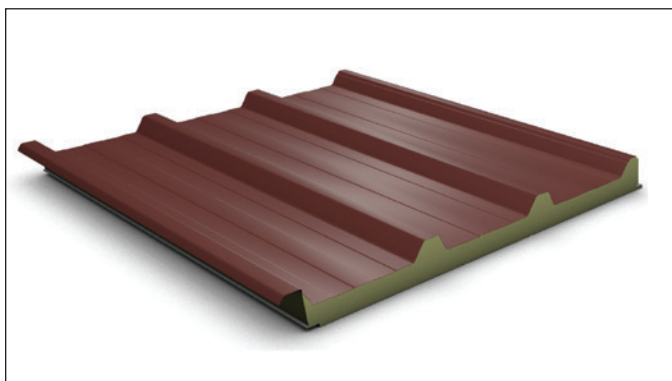

Panel tolerances

Cutting length: ± 5 - 10 mm (in relation to the panel's length)

Width: ±2 mm

Thickness: ±2 mm (D≤100 mm) - 2% (D>100 mm)

End square: 6%

Overlap: 50 - 270 mm

Overlap type: Right = Δ and the Left = A.

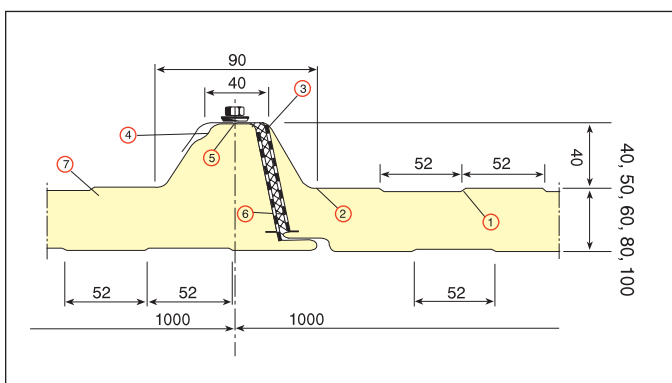

Panel type	Sheet thickness (mm)		Panel's thickness D (mm)	Panel's weight (kg/m ²)	Heat transmission coefficient U (W/m ² * K)	Maximum production length (m)
	Outer	Inner				
RL 30	0,45	0,40	30	8,32	0,65	16,00
RL 40	0,45	0,40	40	8,70	0,50	
RL 50	0,45	0,40	50	9,08	0,41	
RL 60	0,45	0,40	60	9,46	0,35	
RL 80	0,45	0,40	80	10,22	0,26	
RL 100	0,45	0,40	100	10,98	0,21	

Thermal conductivity «λ» = 0,02 W/m*K

ECOPANEL® WLC (wall panel - concealed fix)



Special technical characteristics

- 1 Modern external aesthetic options in four different configurations.
- 2 Secured concealed fix with a normal drill screw.
- 3 Factory-fitted polyurethane foam tape in the female side of overlap for a greater jointing airtightness.
- 4 Side aluminum tape to prevent gases from escaping from the polyurethane cells during the maturation of the foam, resulting in better thermal insulation behavior of the panel over time.
- 5 Environmentally friendly and non-ozone depleting CFC Free & HCFC Free polyurethane foam.

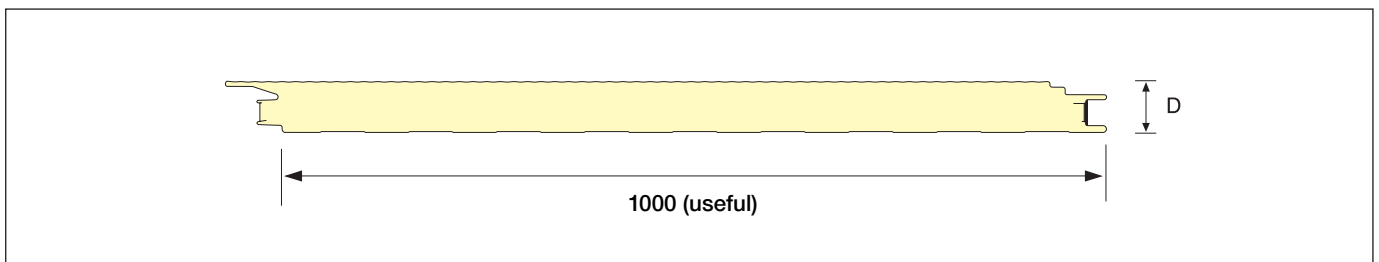
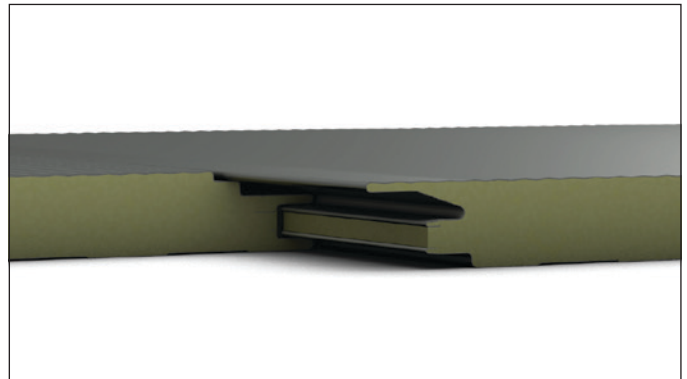
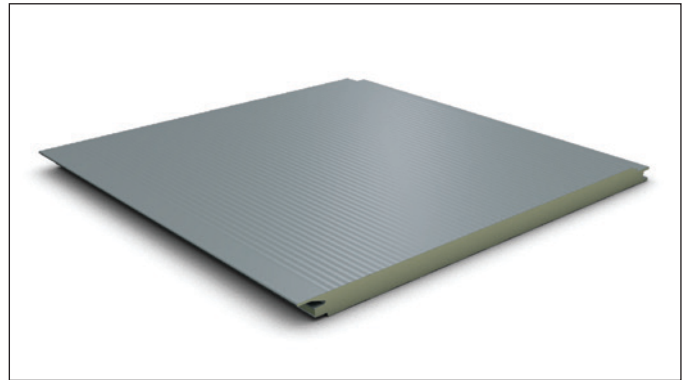

Panel tolerances

Cutting length: ± 5 - 10 mm (in relation to the panel's length)

Width: ± 2 mm

Thickness: ± 2 mm (D ≤ 100 mm) - 2% (D > 100 mm)

End square: 6%

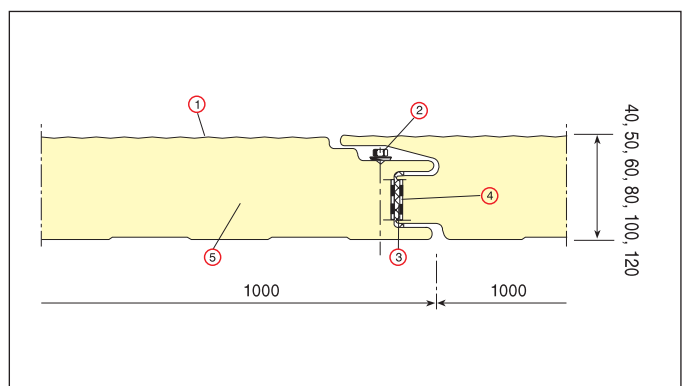

Panel type	Sheet thickness (mm)		Panel's thickness D (mm)	Panel's weight (kg/m ²)	Heat transmission coefficient U (W/m ² * K)	Maximum production length (m)
	Outer (mm)	Inner (mm)				
WLC 40	0,45	0,40	40	8,67	0,62	16,00
WLC 50	0,45	0,40	50	9,05	0,48	
WLC 60	0,45	0,40	60	9,43	0,39	
WLC 80	0,45	0,40	80	10,19	0,28	
WLC 100	0,45	0,40	100	10,95	0,22	
WLC 120	0,45	0,40	120	11,71	0,18	

ECOPANEL® WL/FW (wall panel - internal partition - visible fix)



Special technical characteristics

- 1 Appropriate configuration of the sheets and the joint to deal with external influences such as weather conditions, thermal changes, and mechanical strengths.
- 2 Factory-fitted polyurethane foam tape in the female side of overlap for a greater jointing airtightness.
- 3 Side aluminum tape to prevent gases from escaping from the polyurethane cells during the maturation of the foam, resulting in better thermal insulation behavior of the panel over time.
- 4 Environmentally friendly and non-ozone depleting CFC Free & HCFC Free polyurethane foam.

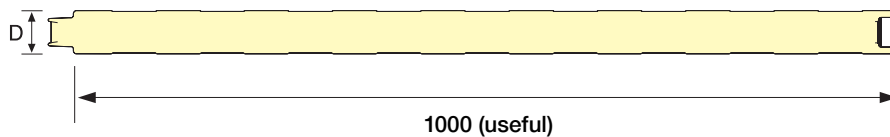
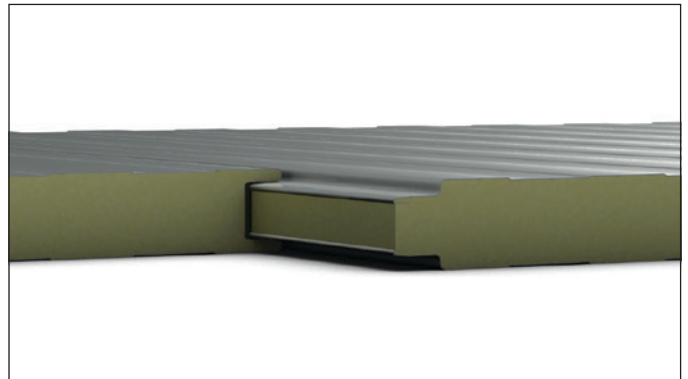
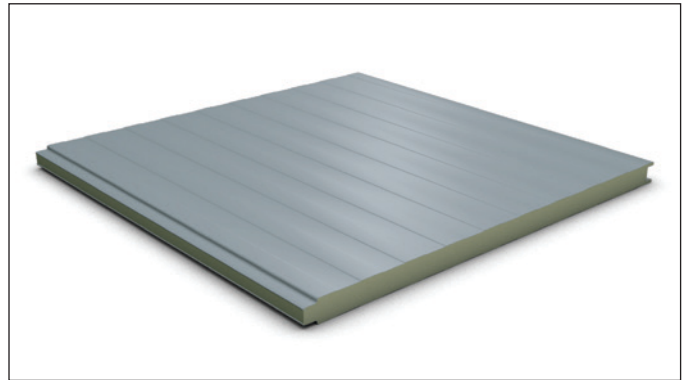

Panel tolerances

Cutting length: $\pm 5 - 10$ mm (in relation to the panel's length)

Width: ± 2 mm

Thickness: ± 2 mm ($D \leq 100$ mm) - 2% ($D > 100$ mm)

End square: 6%

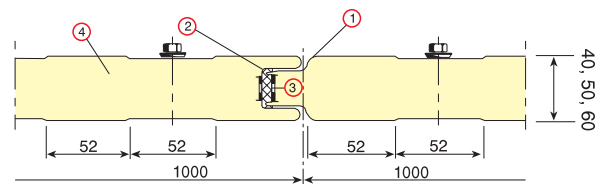

Panel type	Sheet thickness (mm)		Panel's thickness D (mm)	Panel's weight (kg/m ²)	Heat transmission coefficient U (W/m ² * K)	Maximum production length (m)
	Outer	Inner				
WL 40	0,45	0,45	40	8,61	0,51	16,00
WL 50	0,45	0,45	50	8,99	0,42	
WL 60	0,45	0,45	60	9,37	0,35	

Thermal conductivity «λ» = 0,02 W/m*K

AGROPANEL RL (roof panel)



AGROPANEL RL is the series of CORE roof panels specially produced for the coating of animal husbandry facilities with burden interior environment.

Special technical characteristics

- 1 External sheet same as ECOPANEL® RL.
- 2 Internal surface of fiberglass reinforced polyester, of white colour and thickness 0,60 mm.
- 3 Ideal for animal husbandry facilities.

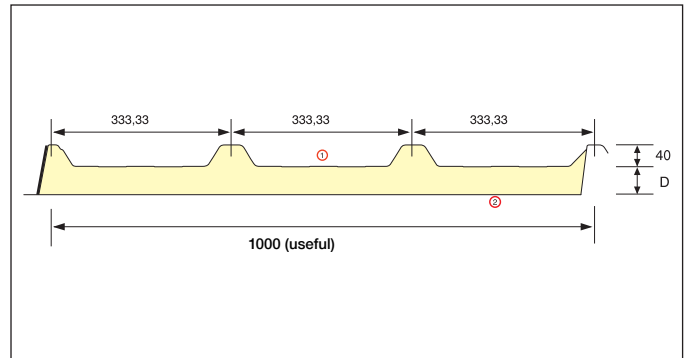

EASYPANEL®

ELASTRON S.A. offers a more economical building solution for every professional and individual with the EASYPANEL® series, of the same geometrical characteristics as ECOPANEL®.

EASYPANEL® RL (roof panel)

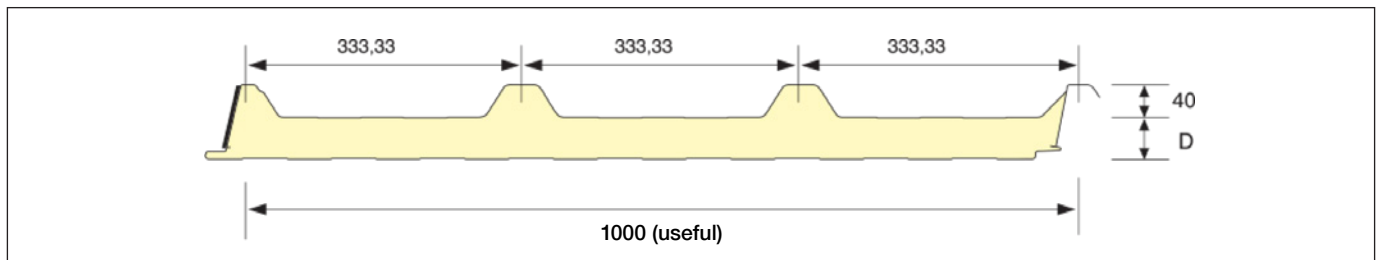

EASYPANEL® WLC (wall panel - concealed fix)

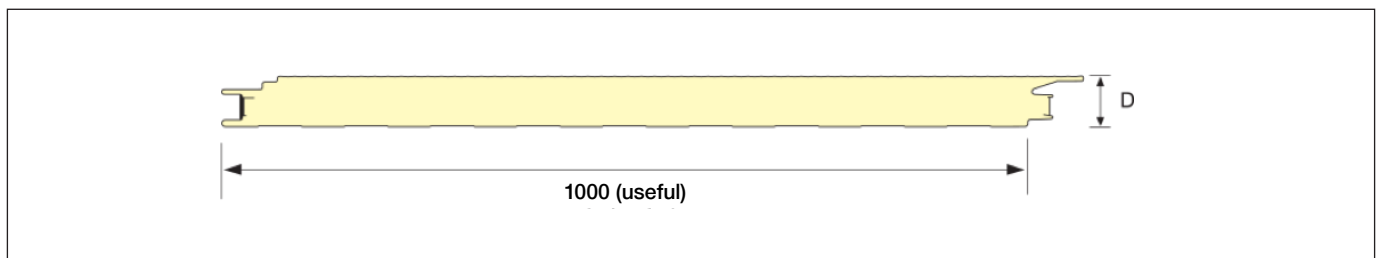

EASYPANEL® WL/FW (wall panel - internal partition - visible fix)

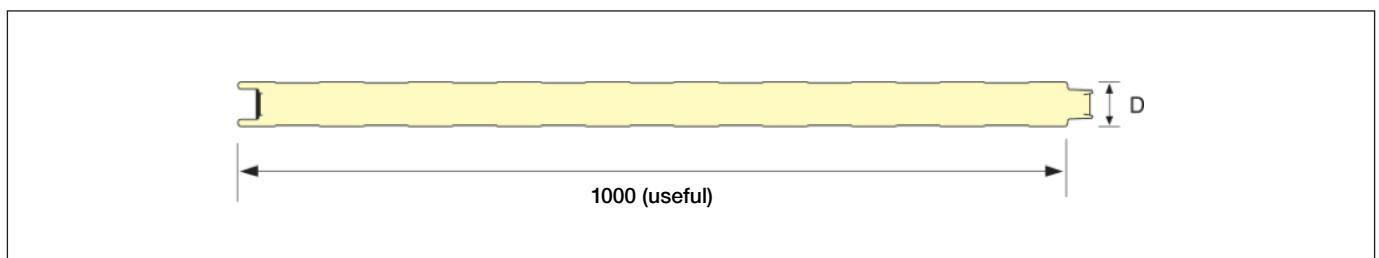

Table of options for all cladding solutions



Panel type	Cladding type				
	Panel type > 3,4°	Roof of internal areas	Vertical wall cladding	Horizontal wall cladding	Temperature controlled rooms
ECOPANEL® RL	✓	-	✓	✓	-
EASYPANEL® RL	✓	-	✓	✓	-
AGROPANEL RL	✓	-	✓	-	-
ECOPANEL® WL/FW	-	✓	✓	✓	-
EASYPANEL® WL/FW	-	✓	✓	-	-
ECOPANEL® WLC	-	✓	✓	✓	-
EASYPANEL® WLC	-	✓	✓	✓	-
ECOPANEL® FL	-	✓	-	-	✓

Inclination > 3,4° for roof without overlapping. Inclination > 5,7° for roof with overlapping.

Technical specifications

Sheets (ECOPANEL® - external AGROPANEL RL)

BASIC SHEET TYPE

Steel S220GD - S320GD (EN 10346).

SHEET PROTECTION

Hot-dip galvanizing Z100 (100gr/m²) - Z275 (275gr/m²) (EN 10346).

BASIC COATING TYPE

Polyester paint (Polyester – SP) of total thickness 25µm (EN 10169), PVC Food-Safe (sanitary type - internal areas).

OTHER COATING OPTIONS

PVDF / Special Coatings (upon request).

INNER SURFACE AGROPANEL RL

Fiberglass reinforced polyester sheet, of white colour and thickness 0,60 mm.

Polyurethane foam (PUR) / Polyisocyanurate foam (PIR)

PHYSICAL FOAM CHARACTERISTICS

no smell, chemically neutral, mould free, not affected by moisture, no hygroscopic.

FOAM SWELLING

Through non aggravating components for the environment (CFC Free & HCFC Free).

Thermal insulated panel ECOPANEL® / EASYPANEL®

Produced according to the European Standard EN 14509 and bears the CE mark.

FOAM DENSITY

40 ± 2 Kgr/m³.

FOAM TYPE

PUR & PIR.

FIRE CLASS (PIR)

B-s2/s3,d0 kará EN 13501-1.

FIRE RESISTANCE (PIR)

REI-30 / EI-30 according to EN 13501-2 (for thicknesses ≥ 80 mm)

Metal sheets options / colours



Pre-painted metal sheets are used for the production of thermal insulated panels.

The steel is primarily selected based on increased mechanical strength and durability in shaping, and secondarily, the aluminum for projects of special specifications and upon particular order.

The main categories of steel used are:

- S 220 GD
- S 250 GD
- S 280 GD
- S 320 GD

The thickness of the sheets used to produce ECOPANEL ranges from 0,40 mm to 0,75 mm.

Particularly:

- ECOPANEL® RL - roof panel: external and internal sheet thickness range from 0,40 mm to 0,75 mm.
- ECOPANEL® WL/FW - wall panel - internal partition - visible fix: external and internal sheet thickness range from 0,40 mm to 0,75 mm.
- ECOPANEL® WLC - wall panel - concealed fix: external sheet thickness range from 0,40 mm to 0,60 mm and internal sheet thickness range from 0,40 mm to 0,75 mm.
- ECOPANEL® FL - cold room panel - concealed fix: external and internal sheet thickness range from 0,40 mm to 0,75 mm.

RAL Colour chart

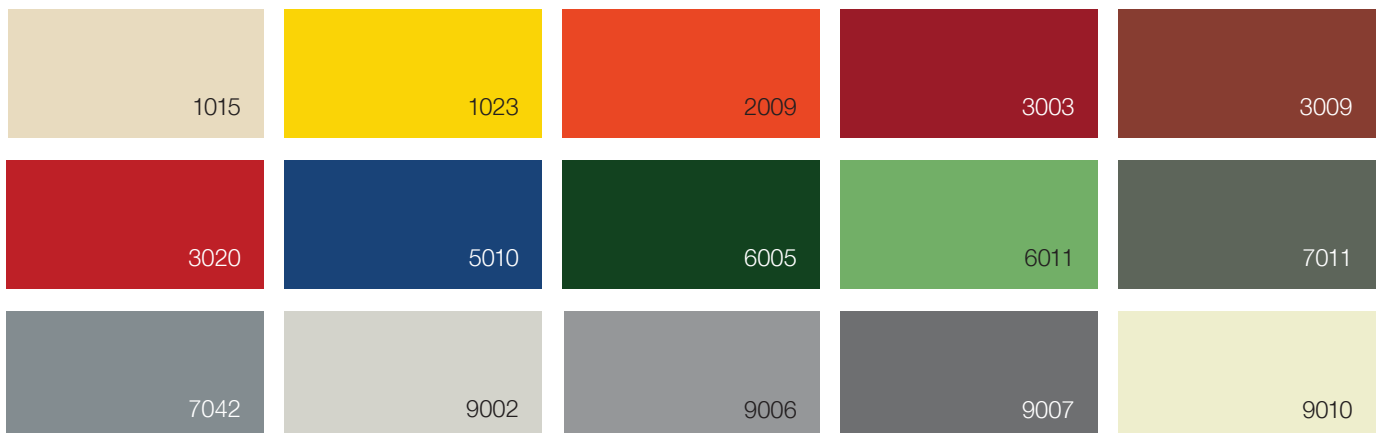

The steel sheets with Polyester (SP) coating are in stock in the basic colours of the RAL scale. For steel sheets with different coating and other colour range please contact the sales department.

The steel sheet's thickness of the economical series EASYPANEL® is $\leq 0,35$ mm in order to reduce construction costs, provided there are appropriate conditions and circumstances.

Final coating (paint) steel sheets qualities

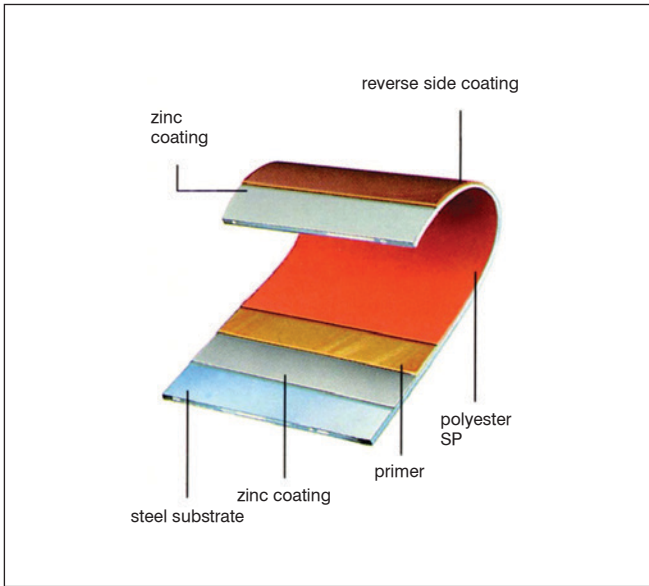

Polyester (SP)

- Anti-corrosion protection.
- Suitable for normal environmental conditions (non-polluting).
- Total coating thickness 25 µm.

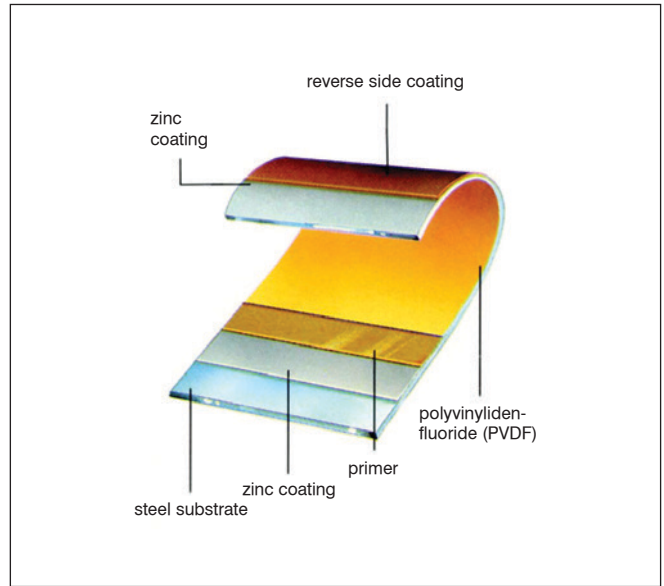

Polyvinylidene-Fluoride (PVDF)

- Increased anti-corrosion protection.
- Increased UV protection.
- Total coating thickness 25µm - 50µm.

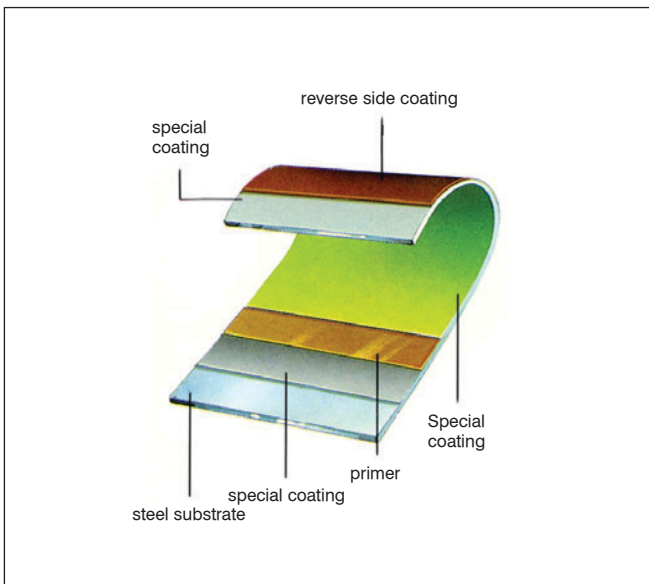

Special Coatings

- Special coatings upon request.
- Increased anti-corrosion protection.
- Increased UV protection.
- Total coating thickness 35µm - 60µm.

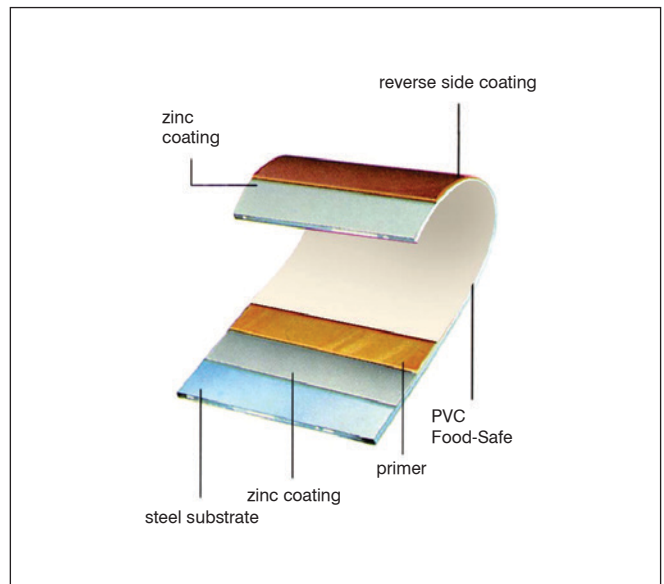

PVC Food-Safe

- Special coating for areas of controlled atmosphere, food processing and storage, laboratories (pharmaceutical, microbiological, etc.).
- Nontoxic anti-bacterial coating.
- Only for internal use (not exposed to UV radiation).
- Total coating thickness 110µm - 120µm.

The information, descriptions, procedures, specifications, and dimensions contained in this catalogue are true and valid until the date of issue. ELASTRON S.A. STEEL SERVICE CENTERS reserves the right to make changes to the design, and the materials of its products for their improvement or removal, without prior notice. Although ELASTRON S.A. STEEL SERVICE CENTERS has made every effort to ensure that the information, technical instructions and data presented in this catalogue are accurate, nevertheless it remains for the user (reader) the obligation to verify whether the above are suitable to cover any of its needs. The company is not liable and is not responsible for any technical or typographical errors that cannot be predicted or have occurred unintentionally or due to force majeure. Especially for the elaboration of particular mechanical engineering studies, we ask you to contact the technical department of our company, in order to receive an updated copy of our catalogue, and to provide you with information and clarifications regarding the data listed in it.

October 2020

ELASTRON S.A.

Agios Ioannis Street, Ag. Ioannis,
193 00, Aspropyrgos , Athens, Greece

Tel. +30 210 5515 000

Fax +30 210 5515 015

elastron@elastron.gr

www.elastron.gr