



**DESIGN TABLES FOR
COMPOSITE SLABS WITH
SYMDECK73 PROFILED
STEEL SHEETING (2016)**

Design manual for composite slabs according to EN 1993.01.03:2006 and EN 1994.01.04: 2005. This manual comes with software which is available in the webpage: www.elastron.gr

COMPOSITE SLABS – AN INTRODUCTION

The composite slabs consist of profiled steel sheeting and reinforced concrete. The composite method of slab construction was first introduced in North America and is increasingly being used in Europe and in Greece.

During the last years the use of composite slabs in civil engineering structures has been increased due to the advantages that it offers with respect to more traditional solutions. The benefits from the usage of composite slabs can be summarized in the following:

- Less construction time is required.
- The usage of wooden formwork is avoided.
- They can be used to bridge larger spans.

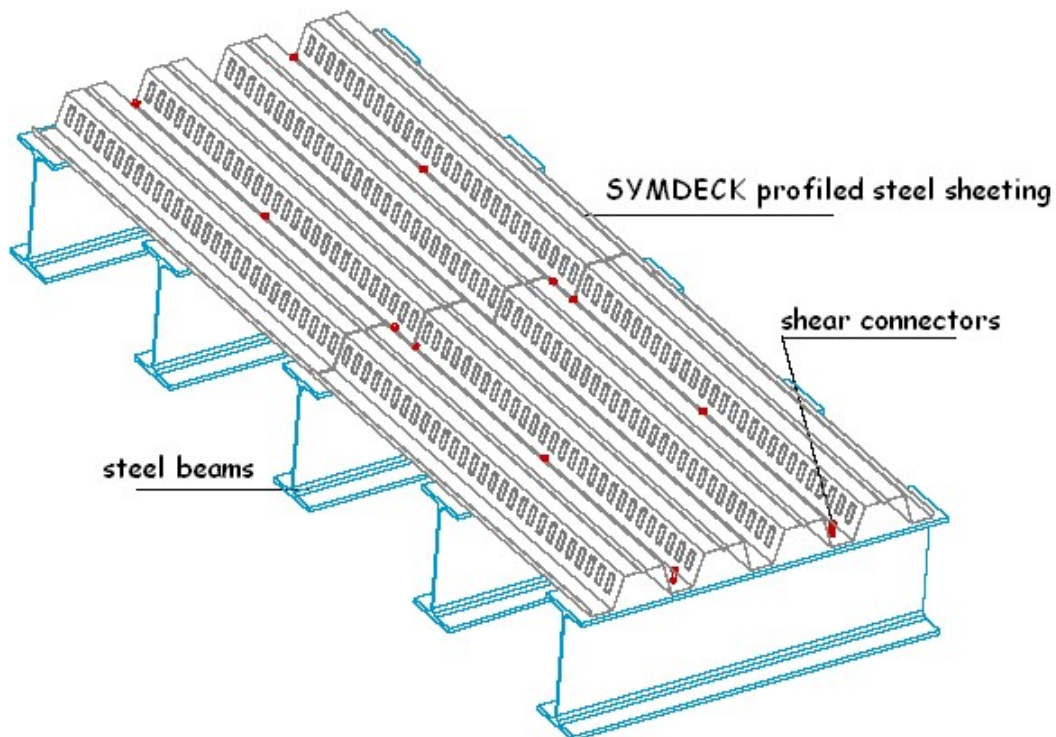

Figure 1: Typical configuration of a composite slab.

The main component of the composite slabs is the profiled steel sheeting which, during the construction phase, functions as formwork supporting the wet concrete (see Figure 1). After the hardening of the concrete, the composite slabs undertake the additional imposed loads. Usually, a light reinforcement is applied to the upper surface of the composite slab (Figure 2) which protects the concrete from cracking. In the case that a continuous beam structural system is adopted, this reinforcement gives also to the composite slab the ability to undertake hogging bending moments at the positions of the supports.

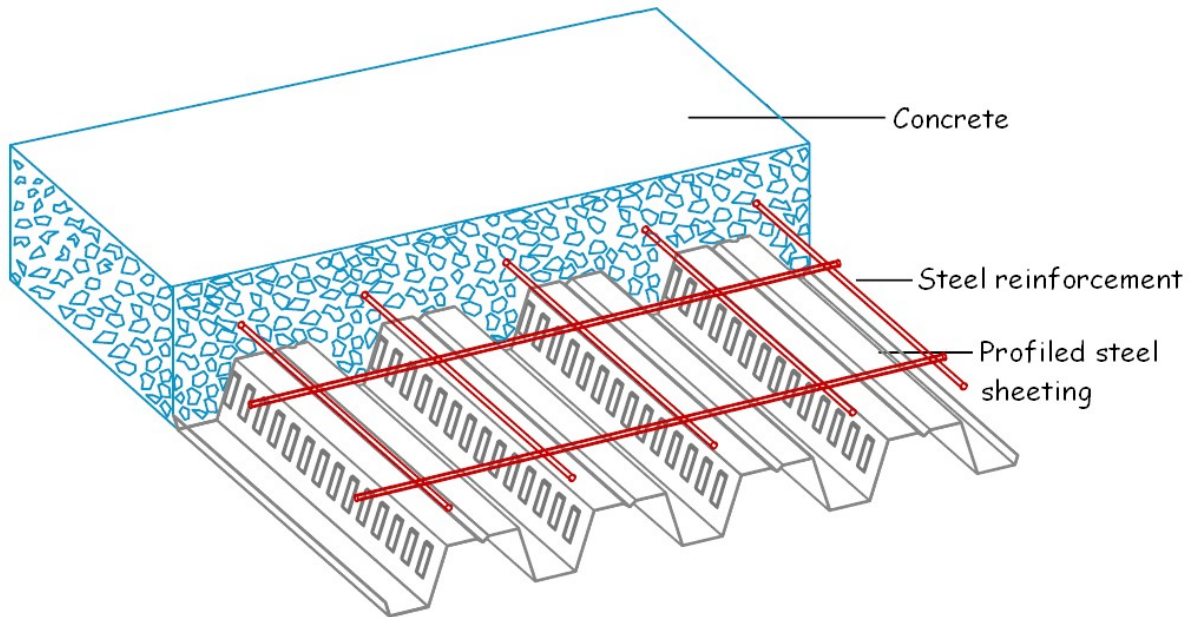

Figure 2: Typical composite slab

THE SYMDECK73 PROFILED STEEL SHEETING

The SYMDECK73 profiled steel sheeting is a galvanized trapezoidal profile which is being used in the construction of large spanning composite slabs. Moreover it can be used alone (i.e. without concrete) as the main structural element for light floors.

The upper surface of the steel sheeting is stiffened against local buckling with an intermediate stiffener in its middle. Within the web of the cross-section there are embossments which offer the extra bond required between the steel sheeting and the concrete in order to transmit the longitudinal shear forces which develop at the interface of the two materials. It should be mentioned that the pure bond between the steel sheeting and the concrete is not considered as effective for the composite action.

Steel sheetings are always manufactured according to the high standards of the factory, with a thickness that varies from 0.75 mm to 1.25 mm. The steel being used is of high quality Fe320G in accordance to Eurocode 3-Part 1.3, galvanized, and can be painted in various colours. The geometrical and inertial properties of the SYMDECK73 profiled steel sheeting for each thickness are presented in Figure 3 and in the following tables.

Thickness	t (mm)	0.75	0.80	1.00	1.25
Weight	G (kg/m)	7.36	7.85	9.81	12.27
Cross section area	A(cm ²)	9.57	10.15	12.72	15.98
Second moment of inertia	I _y (cm ⁴)	82.51	88.00	110.42	138.32
Section modulus	W _y (cm ³)	20.68	22.11	27.74	34.67

Table 1: Geometrical and inertial properties of the SYMDECK73 trapezoidal steel sheeting.

Thickness	t (mm)	0.75	0.80	1.00	1.25
Weight	G (kg/m ²)	9.81	10.47	13.08	16.36
Cross section area	A(cm ² /m)	12.76	13.533	16.96	21.31
Second moment of inertia	I _y (cm ⁴ /m)	110.01	117.33	147.22	184.43
Section modulus	W _y (cm ³ /m)	27.57	29.48	36.99	42.23

Table 2: Geometrical and inertial properties of the SYMDECK73 trapezoidal steel sheeting per meter of width of cross section.

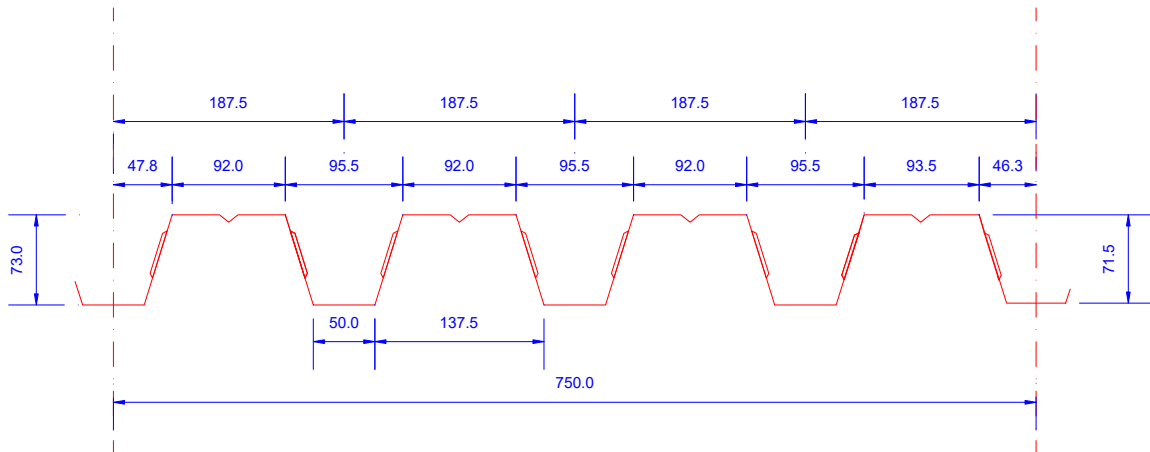

Figure 3: Geometry of the SYMDECK73 trapezoidal steel sheeting

DESIGN OF COMPOSITE SLABS

The design of composite slabs according to Eurocode 4 includes two phases, the “construction phase” and the “phase of the composite action”. During the construction phase, i.e. before the hardening of the concrete, the structural system should have the ability to receive the load of the wet concrete and the extra loads that occur due to the construction. In this case the profiled steel sheeting acts as formwork. After the hardening of the concrete the steel sheeting and the concrete work together as unified cross section. In this phase of the composite action, the extra loads applied on the slab during the construction lifetime, are undertaken by the composite action of the two materials.

Construction Phase

In this phase the design is based on the serviceability and ultimate limit states. In the serviceability state, it is checked that the deflections caused by the design loads are within the limits set in Eurocode 4. In the ultimate limit state, the ability of the steel sheeting to undertake the bending moments caused by the design loads is checked. The ultimate limit state is checked using the provisions of the Part 1.3 of Eurocode 3 that refers to the cold formed thin gauge members and sheeting. In case that the required checks are not fulfilled, there is the possibility to place additional intermediate supports and repeat the required checks. These additional supports are removed after the hardening of the concrete.

Phase of the composite action

In this phase the checks concern the ability of the slab to undertake bending moments (sagging and hogging), vertical shear and longitudinal shear. Also the deflections of the composite slab should comply with the limits set in Eurocode 4. The design against the ultimate limit state aims to the prevention of the failure modes described in the following.

FAILURE MODES OF COMPOSITE SLABS

The composite slabs may fail under one of the failure modes described below:

- Bending failure (critical cross-section I)
- Longitudinal shear failure (critical cross-section II)
- Vertical shear failure (critical cross-section III)

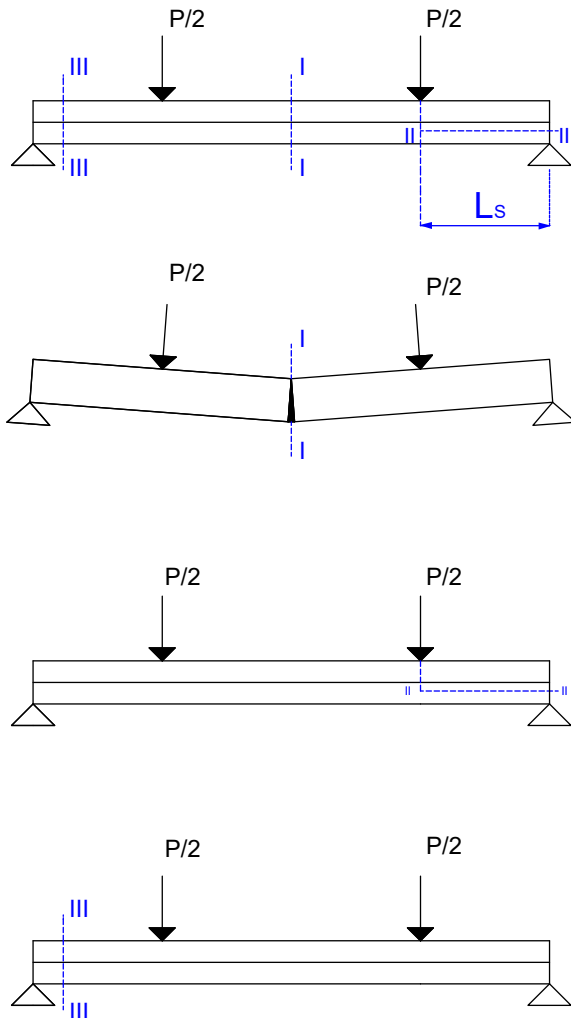

Figure 4: Failure modes of composite slabs.

The steel sheeting plays an important role to the behavior and to the failure modes of composite slabs because it is the factor that determines the type of the shear connection between steel and concrete. According to Eurocode 4, the resistance of the composite slab against longitudinal shear depends on the characteristic stresses m, k which are defined through appropriate experimental testing.

The experimental procedure is specified and described in detail in Eurocode 4. The specimens are simply supported composite slabs, as presented in Figure 5.

Bending failure

The bending failure is achieved only when the full shear connection between the steel sheeting and the concrete is attained. In this case, critical is the cross-section in the middle of the span (cross-section I) where vertical cracking appears.

Longitudinal shear failure

When the longitudinal shear forces that develop in the interface between the steel and the concrete cannot be fully undertaken, the bending strength of the cross section cannot be attained. On the contrary, critical is the horizontal cross-section along the shear length L_s in one of the two supports (cross-section II) in which slippage occurs between the steel sheeting and the concrete. Obviously, the failure in this case occurs for a load smaller than the one for which the bending failure is produced.

Vertical shear failure

The vertical shear failure is critical in composite slabs having rather small span lengths, significant cross-section height and relatively high loads. Critical is the cross-section III.

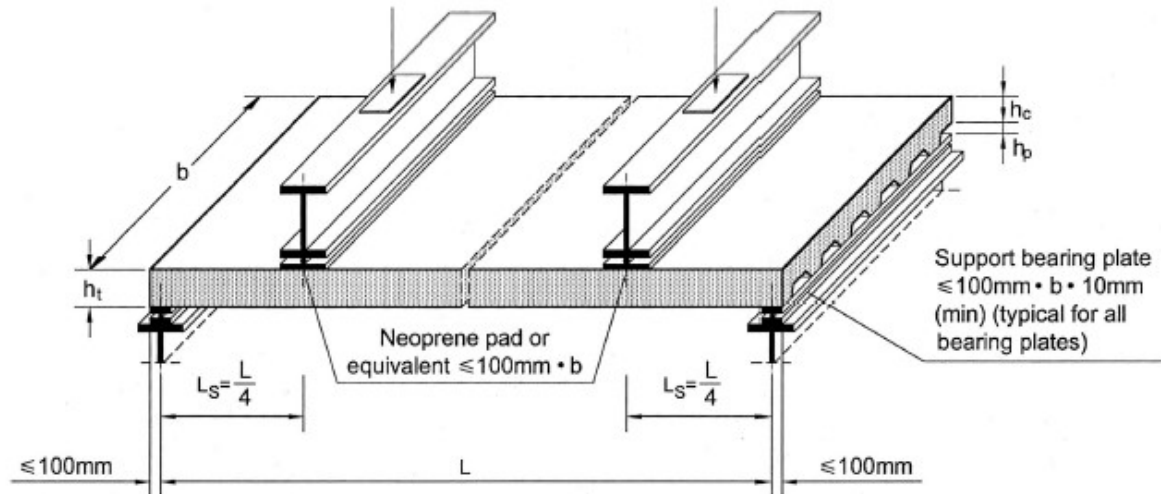

Figure 5: Experimental configuration for the determination of m, k

The simply supported composite slab is loaded with two concentrated loads in an equal distance from the supports so that the shear span of the slab is equal to $L_s = L/4$. Two groups of three tests are conducted. In group A the specimens have a large shear span while in group B they have a small one. The diagram in Figure 6 defines the way that the factors m and k , are determined from the results of the conducted experiments.

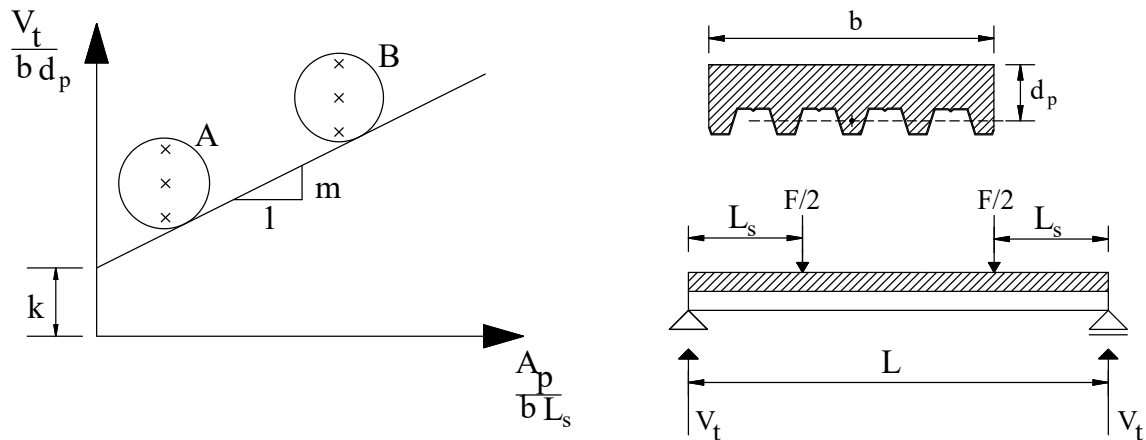

Fig. 6: Determination of the m, k factors

The values of the factors m, k for the SYMDECK73 profiled steel sheeting were determined after a set of experiments on composite slabs. The tests were conducted in the Laboratory of Reinforced Concrete Technology and Structures of the Department of Civil Engineering at the University of Thessaly, Greece, within the framework of a relevant research program. The values were calculated by means of the diagram of Figure 7.

The factors m, k are effective for:

1. Slab thickness equal or smaller than the one used in tests ($d \leq 20cm$).
2. Steel sheeting thickness equal or bigger than the one used in tests ($t \geq 0.75mm$).
3. Concrete with characteristic compressive strength $f_{ck} \geq 20Mpa$ (C20/25 and above).
4. Profile steel sheeting with yield stress $f_y \geq 293MPa$ (practically Fe320G and above).

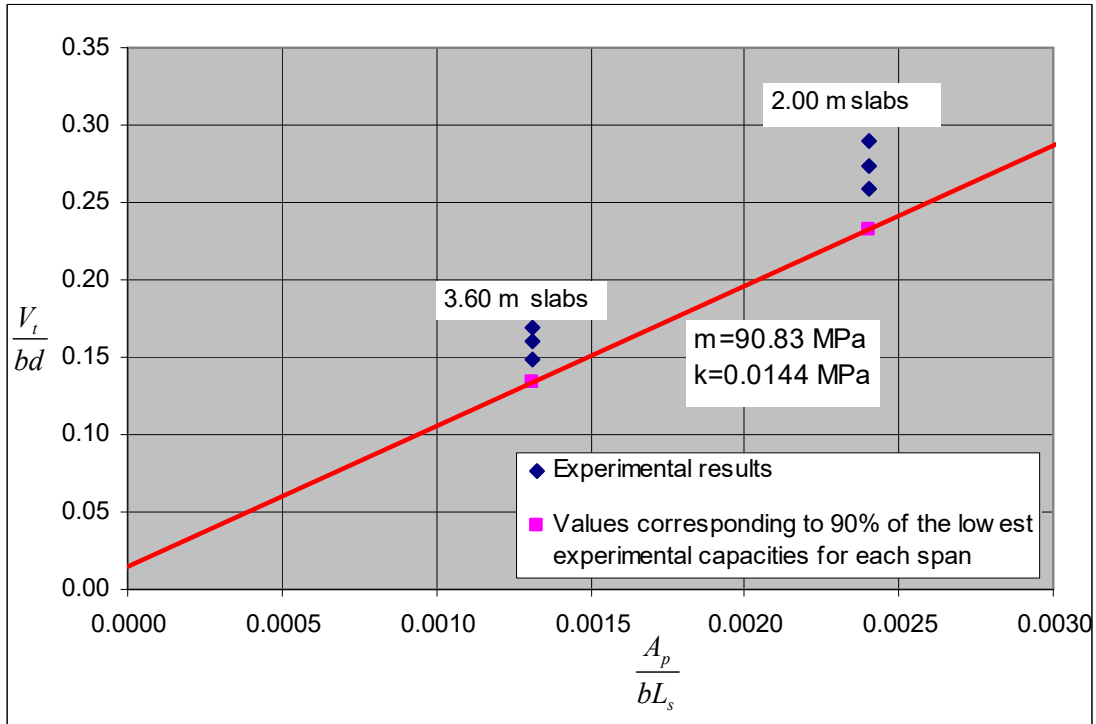

Figure 7: Determination of the factors m, k from the experimental results.

DESIGNING TABLES OF COMPOSITES SLABS WITH SYMDECK73 TRAPEZOIDAL STEEL SHEETING.

The tables which have been created for various SYMDECK73 steel sheeting thickness, concrete qualities and structural systems give the following abilities:

- Determination of the slab thickness required for a certain span length and a certain ultimate load.
- Determination of the maximum span length for a certain value of the slab thickness and a certain ultimate load.
- Determination of the maximum ultimate load for a certain slab thickness and a certain span length.

Also the tables indicate the need for temporary intermediate supports of the steel sheeting during the construction phase and the number of the required supports.

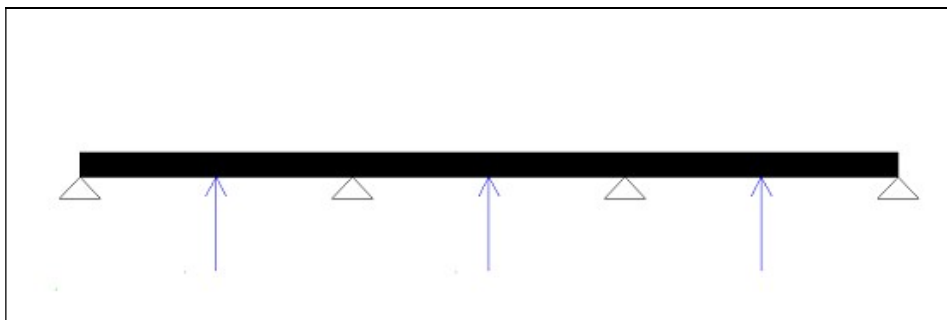

Figure 8: Model of a composite slab with intermediate supports.

The ultimate loads defined in the design tables were calculated with the help of the “SYMDECK Designer” software.

In the construction phase, the bending strengths were calculated according to the Part 1.3 of Eurocode 3, taking into account only the effective areas of the steel sheeting in the places where compressive stresses develop. It is noted that during the calculation of the bending strengths, the areas of the embossments of the steel sheeting are neglected (it is considered that an opening replaces the embossment).

During the construction phase, the steel sheeting supports its self weight, the weight of the wet concrete and the extra construction loads. A temporary support is essential when the design bending moments due to the above loads are greater than the bending moment resistance of the steel sheeting.

For the determination of the design bending moments, the envelope of the moments produced by the various load situations is used. For the determination of the envelope of the bending moments, the following loads are applied:

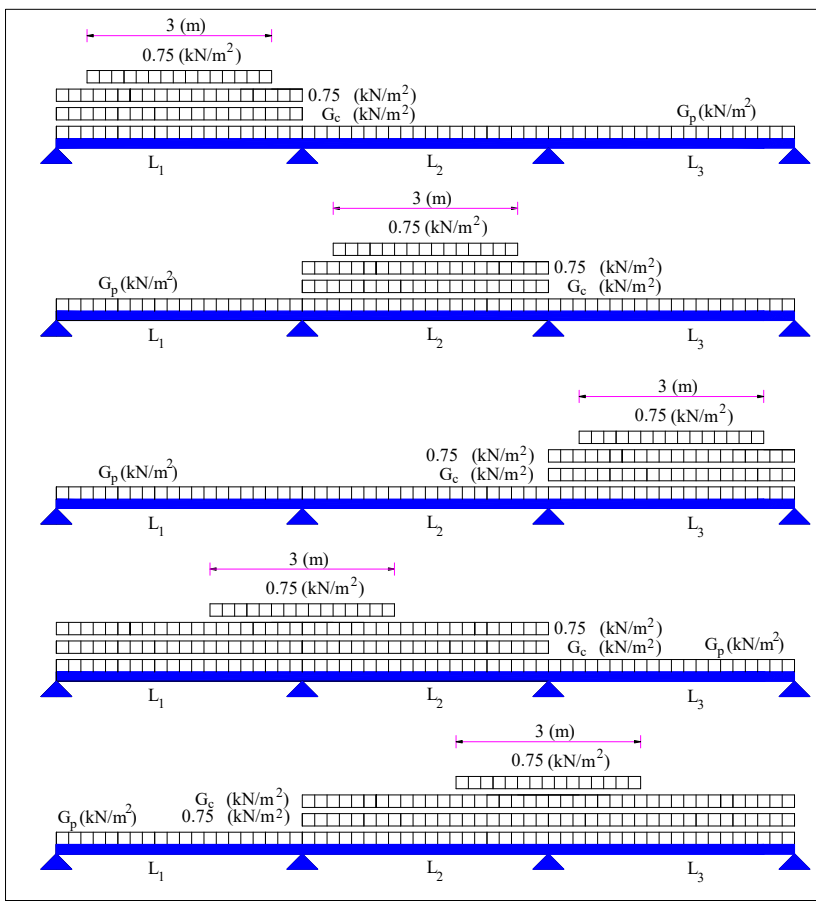

Figure 9: Load combinations for “span-by-span” casting.

- Self weight of the steel sheeting G_p (permanent load)
- Self weight of the concrete (permanent load). Two cases are taken into account in order to consider the self-weight of the concrete:
 - a) The case of a span-by-span casting (first a span is casted with the prescribed concrete thickness, and the casting continues in another span)
 - b) Progressive casting (the slab is casted in layers until the prescribed slab thickness is attained).
- Construction load (variable load)

The construction load is a

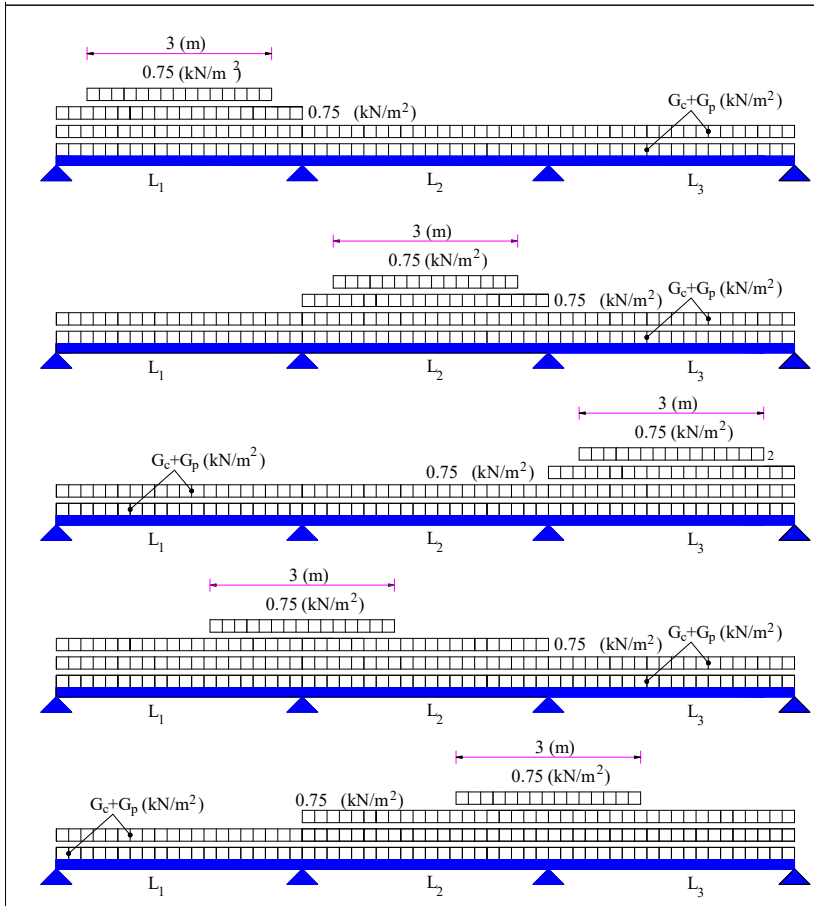

Figure 10: Load combinations for “progressive” casting.

uniformly distributed load of 1.5 kN/m^2 applied on a $3\text{m} \times 3\text{m}$ area (or on the entire span length, if it less than 3m) and a uniformly distributed load of 0.75 kN/m^2 applied on the remaining area. The loads are suitably arranged, depending on whether the ultimate hogging design moment or the sagging design moment is calculated. For the above mentioned loads, the most unfavourable arrangement is considered, as presented in Figures 9 and 10.

For the serviceability limit state, a load safety factor equal to 1.00 is considered.

In the case that the design bending moment is greater than the bending strength of the steel sheeting, the calculations are repeated with a structural system having intermediate supports. In the tables that follow, the span lengths requiring one intermediate support are indicated with yellow colour, while the span lengths requiring two intermediate supports are indicated with orange colour.

In the “composite action” phase the structural system of the composite slab is the initial one, i.e. the one resulting after the removal of the intermediate supports. In this phase, the applied loads in the composite slab are the self weight G , and the variable load Q . For the determination of the internal forces of the composite slab due to the above mentioned loads it is assumed that the variable load Q is applied on the entire area of the slab.

Two states are considered:

- **Ultimate limit state**

It is based on the loading combination $1.35G + 1.50Q$ from which the internal forces E_{sd} are obtained (resistance against sagging moments M_{sd}^+ , resistance against hogging moments M_{sd}^- , resistance against vertical shear $V_{sd,v}$ and resistance against longitudinal shear $V_{sd,l}$)

▪ **Serviceability limit state**

It is based on the load combination $1.00G + 1.00Q$. For the calculation of the displacements, an average value of stiffness of the cracked and the uncracked cross section is used.

The definition of the ultimate variable load Q which is present in the above relations is determined such that:

- None of the design forces exceeds the respective resistances, and
- The displacements of the composite slab are in every span smaller than $L/250$, where L is the span length.

In the following tables the ultimate variable loads Q of the composite slabs were calculated for three different structural systems and for span lengths varying between 1.00 m and 5.50 m.

The design tables were developed in the Department of Civil Engineering of the University of Thessaly, Greece (UTH) within the framework of the research project "DESIGN LOADS FOR COMPOSITE SLABS WITH PROFILED STEEL SHEETING" which was funded by A. ELASTRON S.A.

Project team

Project leader:	E. Mistakidis, Professor of Structural Analysis, Director of the Laboratory of Structural Analysis and Design, email: emistaki@uth.gr, tel. +30-24210-74171, mob. +30-697-4718682
Leader of the experimental project:	P. Perdikaris, Professor of Reinforced Concrete Structures, Director of the Laboratory of Concrete Technology and Reinforced Concrete Structures, email: filperd@uth.gr, tel.+30-24210-74151
Software Development:	K. Dimitriadis, Civil Engineer UTH Greece
Scientific personnel:	Dr. O. Panagouli, Civil Engineer NTUA Greece, Dr. K. Tzaros, Civil Engineer UTH, Dr. D. Pantousa, Civil Engineer UTH A. Giannopoulos, Civil Engineer UTH, K. Papachristou, Civil Engineer UTH

SYMDECK73 – DESIGN TABLES (2016)

	Steel sheeting thickness: t=0.75 mm Concrete: C20/25 Steel reinforcement: S500
---	---

Slab Thickness $h_c(m)$	Span L(m)																		
	1.00	1.25	1.50	1.75	2.00	2.25	2.50	2.75	3.00	3.25	3.50	3.75	4.00	4.25	4.50	4.75	5.00	5.25	5.50
0.13	26.22	20.58	16.82	12.06	8.85	6.64	5.06	3.88	2.98	2.28	1.72	1.26	0.89	0.58					
0.14	28.14	22.07	18.02	13.44	9.87	7.40	5.64	4.32	3.32	2.54	1.91	1.41	0.99	0.65					
0.15	30.00	23.54	19.21	14.82	10.88	8.17	6.22	4.77	3.66	2.80	2.11	1.55	1.10	0.71					
0.16	31.89	24.98	20.37	16.02	11.89	8.93	6.80	5.21	4.00	3.06	2.31	1.70	1.20	0.78					
0.17	33.72	26.40	21.52	17.58	12.90	9.69	7.37	5.66	4.35	3.32	2.51	1.85	1.30	0.85					
0.18	35.52	27.79	22.64	18.96	13.93	10.45	7.95	6.10	4.69	3.58	2.70	1.99	1.41	0.92	0.51				
0.19	37.28	29.16	23.74	19.87	14.93	11.21	8.53	6.55	5.03	3.85	2.90	2.14	1.51	0.99	0.55				
0.20	39.02	30.50	24.82	20.77	15.94	11.97	9.11	6.99	5.37	4.11	3.10	2.28	1.61	1.06	0.59				

Maximum values of the variable load Q (kN/m²)

	Steel sheeting thickness: t=0.80 mm Concrete: C20/25 Steel reinforcement: S500
---	---

Slab Thickness $h_c(m)$	Span L(m)																		
	1.00	1.25	1.50	1.75	2.00	2.25	2.50	2.75	3.00	3.25	3.50	3.75	4.00	4.25	4.50	4.75	5.00	5.25	5.50
0.13	26.75	21.00	17.17	12.85	9.46	7.12	5.442	4.20	3.25	2.50	1.91	1.43	1.04	0.71					
0.14	28.67	22.49	18.37	14.32	10.54	7.93	6.066	4.68	3.62	2.79	2.13	1.60	1.16	0.80					
0.15	30.55	23.95	19.55	15.79	11.62	8.75	6.689	5.16	3.99	3.08	2.35	1.76	1.28	0.88	0.54				
0.16	32.41	25.39	20.72	17.26	12.70	9.56	7.313	5.64	4.36	3.37	2.57	1.93	1.40	0.96	0.59				
0.17	34.23	26.81	21.86	18.32	13.78	10.38	7.936	6.12	4.74	3.66	2.79	2.10	1.52	1.05	0.64				
0.18	36.02	28.20	22.98	19.25	14.86	11.19	8.56	6.60	5.11	3.94	3.01	2.26	1.64	1.13	0.70				
0.19	37.79	29.56	24.08	20.16	15.94	12.01	9.183	7.08	5.48	4.23	3.23	2.43	1.76	1.21	0.75				
0.20	39.52	30.9	25.16	21.05	17.03	12.82	9.807	7.57	5.86	4.52	3.45	2.59	1.89	1.30	0.80				

Maximum values of the variable load Q (kN/m²)

	One intermediate support is required
	Two intermediate supports are required

SYMDECK73 – DESIGN TABLES (2016)

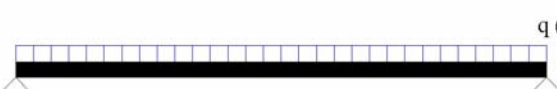
	Steel sheeting thickness: t=1.00 mm Concrete: C20/25 Steel reinforcement: S500
---	---

Slab Thickness h_c (m)	Span L(m)																		
	1.00	1.25	1.50	1.75	2.00	2.25	2.50	2.75	3.00	3.25	3.50	3.75	4.00	4.25	4.50	4.75	5.00	5.25	5.50
0.13	28.77	22.62	18.51	15.58	12.2	9.31	7.21	5.66	4.47	3.54	2.81	2.21	1.72	1.31	0.97	0.68			
0.14	30.68	24.09	19.71	16.57	13.6	10.38	8.04	6.31	4.98	3.95	3.13	2.47	1.92	1.47	1.09	0.76			
0.15	32.55	25.55	20.88	17.55	15.03	11.44	8.87	6.96	5.50	4.36	3.46	2.72	2.12	1.62	1.20	0.84	0.54		
0.16	34.39	26.98	22.03	18.50	15.9	12.51	9.69	7.61	6.01	4.77	3.78	2.98	2.32	1.77	1.32	0.93	0.59		
0.17	36.20	28.38	23.16	19.44	16.6	13.58	10.52	8.26	6.53	5.18	4.10	3.24	2.52	1.93	1.43	1.01	0.65		
0.18	37.98	29.76	24.28	20.36	17.4	14.64	11.35	8.91	7.04	5.59	4.43	3.49	2.72	2.08	1.55	1.09	0.70		
0.19	39.73	31.11	25.37	21.26	18.2	15.71	12.18	9.56	7.56	6.00	4.75	3.75	2.92	2.24	1.66	1.17	0.75		
0.20	41.45	32.44	26.44	22.15	18.9	16.43	13.01	10.2	8.07	6.4	5.08	4.00	3.12	2.39	1.78	1.25	0.81		

Maximum values of the variable load Q (kN/m²)

	Steel sheeting thickness: t=1.25 mm Concrete: C20/25 Steel reinforcement: S500
---	---

Slab Thickness h_c (m)	Span L(m)																		
	1.00	1.25	1.50	1.75	2.00	2.25	2.50	2.75	3.00	3.25	3.50	3.75	4.00	4.25	4.50	4.75	5.00	5.25	5.50
0.13	31.31	24.65	20.20	17.02	14.64	11.94	9.34	7.41	5.94	4.80	3.88	3.14	2.54	2.04	1.61	1.25	0.95	0.68	
0.14	33.20	26.11	21.38	18.01	15.47	13.32	10.42	8.27	6.63	5.35	4.33	3.51	2.84	2.28	1.80	1.40	1.06	0.77	0.51
0.15	35.06	27.55	22.55	18.97	16.29	14.20	11.49	9.12	7.32	5.91	4.78	3.88	3.13	2.52	2.00	1.56	1.18	0.85	0.57
0.16	36.88	28.97	23.69	19.92	17.09	14.89	12.57	9.98	8.00	6.46	5.24	4.24	3.43	2.76	2.19	1.71	1.29	0.94	0.63
0.17	38.68	30.36	24.81	20.85	17.87	15.56	13.65	10.83	8.69	7.02	5.69	4.61	3.73	3.00	2.38	1.86	1.41	1.02	0.69
0.18	40.44	31.72	25.91	21.76	18.64	16.22	14.28	11.7	9.38	7.57	6.14	4.98	4.03	3.23	2.57	2.01	1.53	1.11	0.75
0.19	42.17	33.06	26.99	22.65	19.40	16.86	14.84	12.5	10.1	8.13	6.59	5.34	4.32	3.47	2.76	2.16	1.64	1.19	0.81
0.20	43.87	34.38	28.05	23.52	20.13	17.50	15.39	13.4	10.7	8.68	7.04	5.71	4.62	3.71	2.95	2.31	1.76	1.28	0.87

Maximum values of the variable load Q (kN/m²)

	One intermediate support is required
	Two intermediate supports are required

SYMDECK73 – DESIGN TABLES (2016)

	Steel sheeting thickness: t=0.75 mm Concrete: C20/25 Steel reinforcement: S500
---	---

Reinforcement at the positions of hogging moments

h_c (m)	0.13	0.14	0.15	0.16	0.17	0.18	0.19	0.20
Reinforcement	Φ8/20	Φ8/20	Φ8/15	Φ8/15	Φ10/20	Φ10/20	Φ10/15	Φ10/15

Slab Thickness h_c (m)	Span L(m)																		
	1.00	1.25	1.50	1.75	2.00	2.25	2.50	2.75	3.00	3.25	3.50	3.75	4.00	4.25	4.50	4.75	5.00	5.25	5.50
0.13	20.58	16.07	13.06	10.44	7.59	5.24	4.23	3.19	2.39	1.77	1.27	0.87	0.54						
0.14	22.08	17.22	13.98	11.63	8.46	6.28	4.72	3.55	2.67	1.97	1.42	0.97	0.61						
0.15	23.54	18.35	14.88	12.41	9.33	6.93	5.20	3.92	2.94	2.18	1.57	1.08	0.67						
0.16	24.99	19.46	15.77	13.14	10.20	7.57	5.68	4.28	3.22	2.38	1.72	1.18	0.73						
0.17	26.40	20.54	16.64	13.85	11.07	8.22	6.17	4.65	3.49	2.58	1.86	1.28	0.80						
0.18	27.79	21.61	17.49	14.55	11.93	8.86	6.65	5.01	3.76	2.79	2.01	1.38	0.86						
0.19	29.16	22.66	18.33	15.23	12.80	9.51	7.14	5.38	4.04	2.99	2.16	1.48	0.93						
0.20	30.50	23.69	19.15	15.91	13.47	10.15	7.62	5.75	4.31	3.19	2.31	1.58	0.99	0.50					

Maximum values of the variable load Q (kN/m²)

	Steel sheeting thickness: t=0.80 mm Concrete: C20/25 Steel reinforcement: S500
---	---

Reinforcement at the positions of hogging moments

h_c (m)	0.13	0.14	0.15	0.16	0.17	0.18	0.19	0.20
Reinforcement	Φ8/20	Φ8/20	Φ8/15	Φ8/15	Φ10/20	Φ10/20	Φ10/15	Φ10/15

Slab Thickness h_c (m)	Span L(m)																		
	1.00	1.25	1.50	1.75	2.00	2.25	2.50	2.75	3.00	3.25	3.50	3.75	4.00	4.25	4.50	4.75	5.00	5.25	5.50
0.13	21.00	16.40	13.34	11.13	8.12	6.05	4.57	3.47	2.62	1.97	1.44	1.02	0.67						
0.14	22.49	17.55	14.25	11.90	9.05	6.75	5.09	3.86	2.93	2.19	1.61	1.14	0.75						
0.15	23.95	18.68	15.16	12.64	9.98	7.44	5.62	4.26	3.23	2.42	1.78	1.26	0.83						
0.16	25.39	19.78	16.04	13.37	10.91	8.13	6.10	4.66	3.53	2.65	1.95	1.38	0.91	0.52					
0.17	26.81	20.87	16.91	14.08	11.84	8.83	6.66	5.06	3.83	2.87	2.11	1.50	0.99	0.57					
0.18	28.20	21.93	17.76	14.78	12.54	9.52	7.19	5.46	4.13	3.10	2.28	1.61	1.07	0.61					
0.19	29.56	22.98	18.59	15.46	13.11	10.21	7.71	5.85	4.44	3.33	2.45	1.73	1.15	0.66					
0.20	30.90	24.01	19.41	16.13	13.67	10.90	8.24	6.25	4.74	3.55	2.61	1.85	1.23	0.71					

Maximum values of the variable load Q (kN/m²)

	One intermediate support is required
	Two intermediate supports are required

SYMDECK73 – DESIGN TABLES (2016)

	Steel sheeting thickness: t=1.00 mm Concrete: C20/25 Steel reinforcement: S500
---	---

Reinforcement at the positions of hogging moments

h_c (m)	0.13	0.14	0.15	0.16	0.17	0.18	0.19	0.20
Reinforcement	Φ8/20	Φ8/20	Φ8/15	Φ8/15	Φ10/20	Φ10/20	Φ10/15	Φ10/15

Slab Thickness h_c (m)	Span L(m)																		
	1.00	1.25	1.50	1.75	2.00	2.25	2.50	2.75	3.00	3.25	3.50	3.75	4.00	4.25	4.50	4.75	5.00	5.25	5.50
0.13	22.62	17.69	14.41	12.06	10.08	7.55	5.73	4.39	3.37	2.57	1.94	1.43	1.01	0.67					
0.14	24.09	18.83	15.32	12.81	10.93	8.47	6.44	4.93	3.79	2.90	2.19	1.62	1.15	0.77					
0.15	25.55	19.95	16.21	13.54	11.54	9.83	7.55	5.86	4.56	3.56	2.76	2.11	1.58	1.13	0.76				
0.16	26.98	21.04	17.09	14.26	12.15	10.50	8.26	6.40	4.99	3.89	3.02	2.31	1.73	1.24	0.84				
0.17	28.38	22.12	17.95	14.97	12.74	11.00	8.96	6.95	5.42	4.23	3.28	2.51	1.88	1.35	0.91	0.54			
0.18	29.76	23.18	18.79	15.66	13.31	11.48	9.67	7.50	5.85	4.56	3.53	2.71	2.02	1.46	0.98	0.58			
0.19	31.11	24.22	19.62	16.34	13.88	11.96	10.37	8.05	6.28	4.89	3.79	2.90	2.17	1.57	1.06	0.63			
0.20	32.44	25.24	20.43	17.00	14.43	12.43	10.83	8.60	6.70	5.23	4.05	3.10	2.32	1.68	1.13	0.67			

Maximum values of the variable load Q (kN/m²)

	Steel sheeting thickness: t=1.25 mm Concrete: C20/25 Steel reinforcement: S500
---	---

Reinforcement at the positions of hogging moments

h_c (m)	0.13	0.14	0.15	0.16	0.17	0.18	0.19	0.20
Reinforcement	Φ8/20	Φ8/20	Φ8/15	Φ8/15	Φ10/20	Φ10/20	Φ10/15	Φ10/15

Slab Thickness h_c (m)	Span L(m)																		
	1.00	1.25	1.50	1.75	2.00	2.25	2.50	2.75	3.00	3.25	3.50	3.75	4.00	4.25	4.50	4.75	5.00	5.25	5.50
0.13	24.65	19.31	15.75	13.21	10.02	7.49	5.68	4.35	3.33	2.53	1.91	1.40	0.98	0.64					
0.14	26.11	20.44	16.66	13.95	11.26	8.42	6.39	4.89	3.75	2.86	2.16	1.59	1.12	0.74					
0.15	27.55	21.54	17.54	14.68	12.54	10.87	9.53	7.60	5.99	4.74	3.74	2.94	2.28	1.74	1.28	0.90	0.57		
0.16	28.97	22.63	18.41	15.39	13.13	11.37	9.96	8.40	6.63	5.25	4.15	3.27	2.54	1.94	1.44	1.11	0.65		
0.17	30.36	23.70	19.26	16.09	13.71	11.86	10.38	9.17	7.34	5.86	4.68	3.73	2.94	2.30	1.75	1.29	0.89	0.55	
0.18	31.72	24.75	20.10	16.77	14.29	12.35	10.80	9.53	7.92	6.32	5.05	4.02	3.18	2.48	1.89	1.39	0.97	0.60	
0.19	33.06	25.77	20.91	17.44	14.84	12.82	11.20	9.87	8.50	6.79	5.42	4.32	3.42	2.67	2.04	1.50	1.04	0.65	
0.20	34.38	26.78	21.72	18.10	15.39	13.28	11.59	10.21	9.06	7.25	5.80	4.62	3.65	2.85	2.18	1.61	1.12	0.70	

Maximum values of the variable load Q (kN/m²)

	One intermediate support is required
	Two intermediate supports are required

SYMDECK73 – DESIGN TABLES (2016)

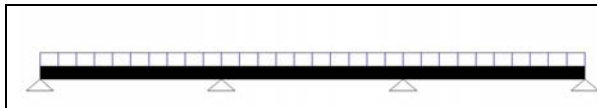

Steel sheeting thickness: **t=0.75 mm**
 Concrete: C20/25
 Steel reinforcement: S500

Reinforcement at the positions of hogging moments

h_c (m)	0.13	0.14	0.15	0.16	0.17	0.18	0.19	0.20
Reinforcement	Φ8/20	Φ8/20	Φ8/15	Φ8/15	Φ10/20	Φ10/20	Φ10/15	Φ10/15

Slab Thickness h_c (m)	Span L(m)																		
	1.00	1.25	1.50	1.75	2.00	2.25	2.50	2.75	3.00	3.25	3.50	3.75	4.00	4.25	4.50	4.75	5.00	5.25	5.50
0.13	21.53	16.82	13.69	10.96	7.99	5.95	4.49	3.40	2.57	1.93	1.41	0.99	0.65						
0.14	23.09	18.03	14.66	12.21	8.91	6.64	5.00	3.79	2.87	2.15	1.57	1.11	0.72						
0.15	24.63	19.21	15.61	13.03	9.82	7.32	5.52	4.18	3.16	2.37	1.73	1.22	0.80						
0.16	26.14	20.38	16.54	13.80	10.73	8.00	6.03	4.57	3.46	2.59	1.90	1.34	0.88						
0.17	27.62	21.52	17.45	14.55	11.65	8.68	6.55	4.96	3.76	2.81	2.06	1.45	0.95	0.54					
0.18	29.08	22.64	18.35	15.29	12.56	9.36	7.06	5.35	4.05	3.03	2.22	1.57	1.03	0.58					
0.19	30.52	23.75	19.23	16.01	13.48	10.04	7.57	5.74	4.35	3.25	2.38	1.68	1.10	0.62					
0.20	31.92	24.83	20.10	16.72	14.18	10.72	8.09	6.13	4.60	3.48	2.55	1.80	1.18	0.67					

Maximum values of the variable load Q (kN/m²)

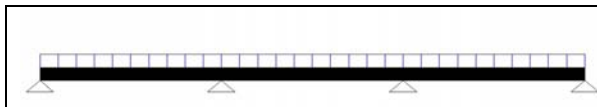

Steel sheeting thickness: **t=0.80 mm**
 Concrete: C20/25
 Steel reinforcement: S500

Reinforcement at the positions of hogging moments

h_c (m)	0.13	0.14	0.15	0.16	0.17	0.18	0.19	0.20
Reinforcement	Φ8/20	Φ8/20	Φ8/15	Φ8/15	Φ10/20	Φ10/20	Φ10/15	Φ10/15

Slab Thickness h_c (m)	Span L(m)																		
	1.00	1.25	1.50	1.75	2.00	2.25	2.50	2.75	3.00	3.25	3.50	3.75	4.00	4.25	4.50	4.75	5.00	5.25	5.50
0.13	21.96	17.17	13.98	11.68	8.55	6.39	4.84	3.69	2.82	2.13	1.59	1.15	0.78						
0.14	23.52	18.37	14.94	12.49	9.52	7.12	5.40	4.12	3.14	2.38	1.77	1.28	0.88	0.54					
0.15	25.05	19.55	15.89	13.27	10.50	7.85	5.95	4.54	3.46	2.62	1.95	1.41	0.97	0.60					
0.16	26.56	20.72	16.82	14.04	11.48	8.58	6.51	4.96	3.79	2.87	2.14	1.55	1.06	0.65					
0.17	28.04	21.86	17.73	14.79	12.46	9.32	7.06	5.39	4.11	3.11	2.32	1.68	1.15	0.71					
0.18	29.50	22.98	18.63	15.52	13.19	10.05	7.62	5.81	4.44	3.36	2.50	1.81	1.24	0.77					
0.19	30.93	24.08	19.51	16.24	13.80	10.78	8.17	6.24	4.76	3.61	2.69	1.94	1.33	0.83					
0.20	32.34	25.16	20.37	16.95	14.39	11.51	8.73	6.66	5.08	3.85	2.87	2.08	1.43	0.88					

Maximum values of the variable load Q (kN/m²)

	One intermediate support is required
	Two intermediate supports are required

SYMDECK73 – DESIGN TABLES (2016)

	Steel sheeting thickness: t=1.00 mm Concrete: C20/25 Steel reinforcement: S500
---	---

Reinforcement at the positions of hogging moments

h_c (m)	0.13	0.14	0.15	0.16	0.17	0.18	0.19	0.20
Reinforcement	Φ8/20	Φ8/20	Φ8/15	Φ8/15	Φ10/20	Φ10/20	Φ10/15	Φ10/15

Slab Thickness h_c (m)	Span L(m)																		
	1.00	1.25	1.50	1.75	2.00	2.25	2.50	2.75	3.00	3.25	3.50	3.75	4.00	4.25	4.50	4.75	5.00	5.25	5.50
0.13	23.64	18.51	15.09	12.65	10.82	8.41	6.48	5.04	3.95	3.09	2.41	1.86	1.41	1.04	0.72				
0.14	25.19	19.71	16.05	13.44	11.48	9.38	7.22	5.62	4.40	3.45	2.69	2.08	1.58	1.16	0.81	0.51			
0.15	26.71	20.88	16.99	14.21	12.13	10.34	7.97	6.20	4.86	3.81	2.97	2.30	1.74	1.28	0.90	0.57			
0.16	28.21	22.03	17.91	14.97	12.76	11.05	8.71	6.78	5.31	4.17	3.25	2.51	1.91	1.41	0.98	0.62			
0.17	29.68	23.16	18.82	15.72	13.39	11.58	9.46	7.36	5.77	4.52	3.53	2.73	2.07	1.53	1.07	0.68			
0.18	31.13	24.28	19.71	16.44	14.00	12.09	10.20	7.94	6.22	4.88	3.81	2.95	2.24	1.65	1.16	0.74			
0.19	32.55	25.37	20.58	17.16	14.59	12.60	10.94	8.52	6.68	5.24	4.09	3.17	2.41	1.77	1.24	0.79			
0.20	33.94	26.44	21.43	17.86	15.18	13.09	11.43	9.10	7.13	5.60	4.37	3.38	2.57	1.90	1.33	0.85			

Maximum values of the variable load Q (kN/m²)

	Steel sheeting thickness: t=1.25 mm Concrete: C20/25 Steel reinforcement: S500
---	---

Reinforcement at the positions of hogging moments

h_c (m)	0.13	0.14	0.15	0.16	0.17	0.18	0.19	0.20
Reinforcement	Φ8/20	Φ8/20	Φ8/15	Φ8/15	Φ10/20	Φ10/20	Φ10/15	Φ10/15

Slab Thickness h_c (m)	Span L(m)																		
	1.00	1.25	1.50	1.75	2.00	2.25	2.50	2.75	3.00	3.25	3.50	3.75	4.00	4.25	4.50	4.75	5.00	5.25	5.50
0.13	25.76	20.20	16.49	13.85	11.86	9.88	7.61	5.94	4.67	3.68	2.89	2.26	1.74	1.31	0.95	0.64			
0.14	27.29	21.38	17.44	14.63	12.52	10.88	8.55	6.68	5.25	4.14	3.26	2.55	1.97	1.48	1.08	0.74			
0.15	28.80	22.55	18.37	15.40	13.16	11.42	10.03	8.21	6.54	5.24	4.20	3.37	2.68	2.11	1.63	1.22	0.88	0.58	
0.16	30.28	23.69	19.29	16.15	13.79	11.96	10.49	8.98	7.15	5.73	4.60	3.68	2.93	2.31	1.79	1.34	0.96	0.64	
0.17	31.74	24.81	20.18	16.88	14.41	12.48	10.94	9.68	7.77	6.22	5.00	4.00	3.19	2.51	1.95	1.46	1.05	0.70	
0.18	33.17	25.91	21.06	17.60	15.01	12.99	11.38	10.06	8.38	6.72	5.39	4.32	3.44	2.72	2.10	1.58	1.14	0.76	
0.19	34.76	26.99	21.93	18.31	15.56	13.49	11.80	10.42	9.00	7.21	5.79	4.64	3.70	2.92	2.26	1.70	1.23	0.82	
0.20	35.96	28.05	22.77	19.00	16.18	13.98	12.22	10.78	9.58	7.70	6.19	4.96	3.96	3.12	2.42	1.82	1.31	0.88	

Maximum values of the variable load Q (kN/m²)

	One intermediate support is required
	Two intermediate supports are required

FIRE DESIGN TABLES FOR COMPOSITE SLABS WITH SYMDECK 73 STEEL SHEETING

The fire design is based on the loading combination for accidental design situations given in Eurocode 1 that can be simplified to $G + \psi_2 Q$. Using this combination, the design values for the positive and the negative moment are obtained ($M_{fi,Sd}^+$ and $M_{fi,Sd}^-$ respectively).

The calculations are valid only for the ISO fire curve, as it is defined in Eurocode 3 – Part 1.2 and in the case where the heating rate of the composite slab is between 2 and 50 °K/min.

The values of positive and negative moment resistance of composite slabs are obtained according to the recommendations of Eurocode 4 – Part 1-2 (Annex D).

The maximum value of the variable load Q is determined from the most critical situation, which can be either at room temperature (ultimate or serviceability limit design situation) or for the fire situation (loadbearing criterion R or thermal insulation criterion I). Moreover, the maximum value of Q which is defined in the following tabulated data cannot be greater than the one that is calculated at room temperatures. If the loadbearing criterion R is not satisfied, an additional reinforcement (reinforcement which is placed in the rib of the slab) is determined to cover the bending requirement. The calculations for these reinforcing bars take into account that the bar is located at a height of 30mm above the lower flange of the steel sheeting. The bar is considered to be of high strength steel B500C.

In the case where the composite slab is consistent with the loading bearing criterion R but the thermal insulation criterion is not satisfied, the maximum value for the variable load is marked with a diagonal line.

The following tables refer to three different structural systems (simply supported beam, two-span continuous beam, three-span continuous beam). The minimum value of the span that is considered is 1 m while the maximum one is 5.50 m. The calculations are conducted taking into account a value of the action combination factor $\psi_2 = 0.60$. Moreover the tables consider four different cases, depending on the required fire resistance (requirements R30, R60, R90 and R120).

The software *SYMDECK Designer* can be used for cases that are not included in the following tables. The software is available in the web site www.elastron.gr.

FIRE RESISTANCE: 30 minutes

	Steel sheeting thickness: t=0.75 mm Concrete: C20/25 Steel reinforcement: B500C
---	--

Slab thickness h _c (m)	Span L(m)																		
	1.00	1.25	1.50	1.75	2.00	2.25	2.50	2.75	3.00	3.25	3.50	3.75	4.00	4.25	4.50	4.75	5.00	5.25	5.50
0.13	28.72	22.61	16.95	12.06	8.85	6.64	5.06	3.88	2.98	2.28	1.72	1.26	0.89	0.58					
0.14	30.83	24.21	18.92	13.44	9.87	7.40	5.64	4.32	3.32	2.54	1.91	1.41	0.99	0.65					
0.15	32.82	25.72	20.86	14.82	10.88	8.17	6.22	4.77	3.66	2.80	2.11	1.55	1.10	0.71					
0.16	34.72	27.22	22.12	16.02	11.89	8.93	6.80	5.21	4.00	3.06	2.31	1.70	1.20	0.78					
0.17	36.55	28.71	23.26	17.58	12.90	9.69	7.37	5.66	4.35	3.32	2.51	1.85	1.30	0.85					
0.18	38.40	30.09	24.44	18.96	13.92	10.45	7.95	6.10	4.69	3.58	2.70	1.99	1.41	0.92	0.51				
0.19	40.13	31.43	25.54	20.13	14.93	11.21	8.53	6.55	5.03	3.85	2.90	2.14	1.51	0.99	0.55				
0.20	41.89	32.65	26.72	21.67	15.94	11.97	9.11	6.99	5.37	4.11	3.10	2.28	1.61	1.06	0.59				

Maximum values of the variable load (kN/m²), $\psi_2=0.60$

	Steel sheeting thickness: t=0.80 mm Concrete: C20/25 Steel reinforcement: B500C
---	--

Slab thickness h _c (m)	Span L(m)																		
	1.00	1.25	1.50	1.75	2.00	2.25	2.50	2.75	3.00	3.25	3.50	3.75	4.00	4.25	4.50	4.75	5.00	5.25	5.50
0.13	29.25	23.00	17.87	12.84	9.45	7.11	5.44	4.19	3.24	2.50	1.91	1.43	1.03	0.71					
0.14	31.27	24.79	20.07	14.31	10.53	7.92	6.06	4.67	3.63	2.79	2.13	1.59	1.16	0.79					
0.15	33.55	26.15	21.55	15.78	11.61	8.74	6.68	5.15	3.98	3.07	2.35	1.76	1.28	0.87	0.54				
0.16	35.41	27.79	22.82	17.25	12.69	9.55	7.31	5.63	4.35	3.36	2.57	1.93	1.40	0.96	0.59				
0.17	37.23	29.11	23.96	18.52	13.77	10.37	7.93	6.11	4.73	3.65	2.79	2.09	1.52	1.04	0.64				
0.18	39.02	30.70	25.18	19.98	14.85	11.18	8.56	6.59	5.10	3.93	3.01	2.26	1.64	1.12	0.69				
0.19	40.79	32.06	26.08	21.56	15.94	12.00	9.18	7.07	5.47	4.22	3.23	2.42	1.76	1.21	0.74				
0.20	42.52	33.55	27.19	22.75	17.02	12.81	9.80	7.56	5.85	4.51	3.45	2.59	1.88	1.29	0.80				

Maximum values of the variable load (kN/m²), $\psi_2=0.60$

No additional reinforcement	1ø6	1ø8	1ø10	1ø12	1ø14
-----------------------------	-----	-----	------	------	------

FIRE RESISTANCE: 30 minutes

	Steel sheeting thickness: t=1.00 mm Concrete: C20/25 Steel reinforcement: B500C
---	--

Slab thickness h _c (m)	Span L(m)																		
	1.00	1.25	1.50	1.75	2.00	2.25	2.50	2.75	3.00	3.25	3.50	3.75	4.00	4.25	4.50	4.75	5.00	5.25	5.50
0.13	31.77	24.92	20.51	16.38	12.20	9.30	7.21	5.65	4.46	3.53	2.80	2.20	1.71	1.31	0.96	0.67			
0.14	33.98	26.89	22.01	18.17	13.60	10.37	8.03	6.30	4.97	3.94	3.12	2.46	1.91	1.46	1.08	0.75			
0.15	36.16	28.55	23.38	19.75	15.03	11.44	8.86	6.95	5.49	4.35	3.45	2.71	2.12	1.61	1.19	0.83	0.53		
0.16	38.19	29.98	24.73	20.70	16.32	12.50	9.68	7.60	6.00	4.76	3.77	2.97	2.32	1.76	1.31	0.92	0.58		
0.17	40.20	31.58	25.86	21.94	17.76	13.57	10.51	8.25	6.52	5.17	4.10	3.23	2.52	1.92	1.42	1.00	0.64		
0.18	42.38	33.46	27.28	22.86	19.04	14.63	11.34	8.90	7.03	5.58	4.42	3.48	2.72	2.07	1.54	1.08	0.69		
0.19	44.53	34.91	28.37	23.96	20.55	15.70	12.17	9.55	7.55	5.99	4.74	3.74	2.92	2.23	1.65	1.16	0.74		
0.20	46.45	36.44	29.74	24.95	21.32	16.73	13.00	10.20	8.06	6.39	5.07	4.00	3.12	2.38	1.77	1.24	0.80		

Maximum values of the variable load (kN/m²) , $\psi_2=0.60$

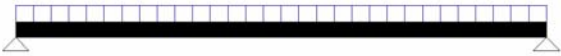
	Steel sheeting thickness: t=1.25 mm Concrete: C20/25 Steel reinforcement: B500C
---	--

Slab thickness h _c (m)	Span L(m)																		
	1.00	1.25	1.50	1.75	2.00	2.25	2.50	2.75	3.00	3.25	3.50	3.75	4.00	4.25	4.50	4.75	5.00	5.25	5.50
0.13	34.31	27.05	22.20	18.72	15.44	11.94	9.34	7.41	5.94	4.79	3.87	3.13	2.53	2.03	1.60	1.24	0.94	0.67	
0.14	36.90	29.01	23.88	20.02	17.27	13.31	10.41	8.26	6.62	5.35	4.32	3.50	2.83	2.27	1.80	1.39	1.05	0.76	0.51
0.15	39.06	30.75	25.35	21.47	18.39	14.59	11.48	9.11	7.31	5.90	4.77	3.87	3.12	2.51	1.99	1.55	1.17	0.84	0.57
0.16	41.68	32.77	26.89	22.62	19.49	15.89	12.56	9.97	8.00	6.45	5.23	4.23	3.42	2.75	2.18	1.70	1.28	0.93	0.62
0.17	43.88	34.36	28.28	23.85	20.47	17.26	13.64	10.82	8.68	7.01	5.68	4.60	3.72	2.99	2.37	1.85	1.40	1.01	0.68
0.18	45.94	34.12	29.51	24.95	21.44	18.77	14.67	11.60	9.37	7.56	6.13	4.97	4.02	3.22	2.56	2.00	1.52	1.10	0.74
0.19	47.97	37.96	30.99	26.05	22.40	19.56	15.64	12.50	10.05	8.12	6.58	5.33	4.31	3.46	2.75	2.15	1.63	1.18	0.80
0.20	49.87	39.58	32.25	27.20	23.13	20.30	16.79	13.35	10.70	8.67	7.03	5.70	4.61	3.70	2.94	2.30	1.75	1.27	0.86

Maximum values of the variable load (kN/m²) , $\psi_2=0.60$

No additional reinforcement	1ø6	1ø8	1ø10	1ø12	1ø14
-----------------------------	-----	-----	------	------	------

FIRE RESISTANCE: 60 minutes

	Steel sheeting thickness: t=0.75 mm Concrete: C20/25 Steel reinforcement: B500C
---	--

Slab thickness h _c (m)	Span L(m)																		
	1.00	1.25	1.50	1.75	2.00	2.25	2.50	2.75	3.00	3.25	3.50	3.75	4.00	4.25	4.50	4.75	5.00	5.25	5.50
0.13	28.72	22.61	16.95	12.06	8.85	6.64	5.06	3.88	2.98	2.28	1.72	1.26	0.89	0.58					
0.14	30.83	24.21	18.92	13.44	9.87	7.40	5.64	4.32	3.32	2.54	1.91	1.41	0.99	0.65					
0.15	32.82	25.72	20.86	14.82	10.88	8.17	6.22	4.77	3.66	2.80	2.11	1.55	1.10	0.71					
0.16	34.72	27.22	22.12	16.02	11.89	8.93	6.80	5.21	4.00	3.06	2.31	1.70	1.20	0.78					
0.17	36.55	28.71	23.26	17.58	12.90	9.69	7.37	5.66	4.35	3.32	2.51	1.85	1.30	0.85					
0.18	38.40	30.09	24.44	18.96	13.92	10.45	7.95	6.10	4.69	3.58	2.70	1.99	1.41	0.92	0.51				
0.19	40.13	31.43	25.54	20.13	14.93	11.21	8.53	6.55	5.03	3.85	2.90	2.14	1.51	0.99	0.55				
0.20	41.89	32.65	26.72	21.67	15.94	11.97	9.11	6.99	5.37	4.11	3.10	2.28	1.61	1.06	0.59				

Maximum values of the variable load (kN/m²) , $\psi_2=0.60$

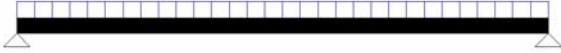
	Steel sheeting thickness: t=0.80 mm Concrete: C20/25 Steel reinforcement: B500C
---	--

Slab thickness h _c (m)	Span L(m)																		
	1.00	1.25	1.50	1.75	2.00	2.25	2.50	2.75	3.00	3.25	3.50	3.75	4.00	4.25	4.50	4.75	5.00	5.25	5.50
0.13	29.25	23.00	17.87	12.84	9.45	7.11	5.44	4.19	3.24	2.50	1.91	1.43	1.03	0.71					
0.14	31.27	24.79	20.07	14.31	10.53	7.92	6.06	4.67	3.63	2.79	2.13	1.59	1.16	0.79					
0.15	33.55	26.15	21.55	15.78	11.61	8.74	6.68	5.15	3.98	3.07	2.35	1.76	1.28	0.87	0.54				
0.16	35.41	27.79	22.82	17.25	12.69	9.55	7.31	5.63	4.35	3.36	2.57	1.93	1.40	0.96	0.59				
0.17	37.23	29.11	23.96	18.52	13.77	10.37	7.93	6.11	4.73	3.65	2.79	2.09	1.52	1.04	0.64				
0.18	39.02	30.70	25.18	19.98	14.85	11.18	8.56	6.59	5.10	3.93	3.01	2.26	1.64	1.12	0.69				
0.19	40.79	32.06	26.08	21.56	15.94	12.00	9.18	7.07	5.47	4.22	3.23	2.42	1.76	1.21	0.74				
0.20	42.52	33.55	27.19	22.75	17.02	12.81	9.80	7.56	5.85	4.51	3.45	2.59	1.88	1.29	0.80				

Maximum values of the variable load (kN/m²) , $\psi_2=0.60$

No additional reinforcement	1ø6	1ø8	1ø10	1ø12	1ø14
-----------------------------	-----	-----	------	------	------

FIRE RESISTANCE: 60 minutes

	Steel sheeting thickness: t=1.00 mm Concrete: C20/25 Steel reinforcement: B500C
---	--

Slab thickness h _c (m)	Span L(m)																		
	1.00	1.25	1.50	1.75	2.00	2.25	2.50	2.75	3.00	3.25	3.50	3.75	4.00	4.25	4.50	4.75	5.00	5.25	5.50
0.13	31.77	24.92	20.51	16.38	12.20	9.30	7.21	5.65	4.46	3.53	2.80	2.20	1.71	1.31	0.96	0.67			
0.14	33.98	26.89	22.01	18.17	13.60	10.37	8.03	6.30	4.97	3.94	3.12	2.46	1.91	1.46	1.08	0.75			
0.15	36.16	28.55	23.38	19.75	15.03	11.44	8.86	6.95	5.49	4.35	3.45	2.71	2.12	1.61	1.19	0.83	0.53		
0.16	38.19	29.98	24.73	20.70	16.32	12.50	9.68	7.60	6.00	4.76	3.77	2.97	2.32	1.76	1.31	0.92	0.58		
0.17	40.20	31.58	25.86	21.94	17.76	13.57	10.51	8.25	6.52	5.17	4.10	3.23	2.52	1.92	1.42	1.00	0.64		
0.18	42.38	33.46	27.28	22.86	19.04	14.63	11.34	8.90	7.03	5.58	4.42	3.48	2.72	2.07	1.54	1.08	0.69		
0.19	44.53	34.91	28.37	23.96	20.55	15.70	12.17	9.55	7.55	5.99	4.74	3.74	2.92	2.23	1.65	1.16	0.74		
0.20	46.45	36.44	29.74	24.95	21.32	16.73	13.00	10.20	8.06	6.39	5.07	4.00	3.12	2.38	1.77	1.24	0.80		

Maximum values of the variable load (kN/m²) , $\psi_2=0.60$

	Steel sheeting thickness: t=1.25 mm Concrete: C20/25 Steel reinforcement: B500C
---	--

Slab thickness h _c (m)	Span L(m)																		
	1.00	1.25	1.50	1.75	2.00	2.25	2.50	2.75	3.00	3.25	3.50	3.75	4.00	4.25	4.50	4.75	5.00	5.25	5.50
0.13	34.31	27.05	22.20	18.72	15.44	11.94	9.34	7.41	5.94	4.79	3.87	3.13	2.53	2.03	1.60	1.24	0.94	0.67	
0.14	36.90	29.01	23.88	20.02	17.27	13.31	10.41	8.26	6.62	5.35	4.32	3.50	2.83	2.27	1.80	1.39	1.05	0.76	0.51
0.15	39.06	30.75	25.35	21.47	18.39	14.59	11.48	9.11	7.31	5.90	4.77	3.87	3.12	2.51	1.99	1.55	1.17	0.84	0.57
0.16	41.68	32.77	26.89	22.62	19.49	15.89	12.56	9.97	8.00	6.45	5.23	4.23	3.42	2.75	2.18	1.70	1.28	0.93	0.62
0.17	43.88	34.36	28.28	23.85	20.47	17.26	13.64	10.82	8.68	7.01	5.68	4.60	3.72	2.99	2.37	1.85	1.40	1.01	0.68
0.18	45.94	34.12	29.51	24.95	21.44	18.77	14.67	11.60	9.37	7.56	6.13	4.97	4.02	3.22	2.56	2.00	1.52	1.10	0.74
0.19	47.97	37.96	30.99	26.05	22.40	19.56	15.64	12.50	10.05	8.12	6.58	5.33	4.31	3.46	2.75	2.15	1.63	1.18	0.80
0.20	49.87	39.58	32.25	27.20	23.13	20.30	16.79	13.35	10.70	8.67	7.03	5.70	4.61	3.70	2.94	2.30	1.75	1.27	0.86

Maximum values of the variable load (kN/m²) , $\psi_2=0.60$

No additional reinforcement	1ø6	1ø8	1ø10	1ø12	1ø14
-----------------------------	-----	-----	------	------	------

FIRE RESISTANCE: 60 minutes

	Steel sheeting thickness: t=0.75 mm Concrete: C20/25 Steel reinforcement: B500C
---	--

Slab thickness h _c (m)	Span L(m)																		
	1.00	1.25	1.50	1.75	2.00	2.25	2.50	2.75	3.00	3.25	3.50	3.75	4.00	4.25	4.50	4.75	5.00	5.25	5.50
0.13	28.72	22.61	18.95	12.06	8.85	6.64	5.06	3.88	2.98	2.28	1.72	1.26	0.89	0.58					
0.14	30.83	24.21	18.92	13.44	9.87	7.40	5.64	4.32	3.32	2.54	1.91	1.41	0.99	0.65					
0.15	32.82	25.72	20.86	14.82	10.88	8.17	6.22	4.77	3.66	2.80	2.11	1.55	1.10	0.71					
0.16	34.72	27.22	22.12	16.02	11.89	8.93	6.80	5.21	4.00	3.06	2.31	1.70	1.20	0.78					
0.17	36.55	28.71	23.26	17.58	12.90	9.69	7.37	5.66	4.35	3.32	2.51	1.85	1.30	0.85					
0.18	38.40	30.09	24.44	18.96	13.92	10.45	7.95	6.10	4.69	3.58	2.70	1.99	1.41	0.92	0.51				
0.19	40.13	31.43	25.54	20.13	14.93	11.21	8.53	6.55	5.03	3.85	2.90	2.14	1.51	0.99	0.55				
0.20	41.89	32.65	26.72	21.67	15.94	11.97	9.11	6.99	5.37	4.11	3.10	2.28	1.61	1.06	0.59				

Maximum values of the variable load (kN/m²) , $\psi_2=0.60$

	Steel sheeting thickness: t=0.80 mm Concrete: C20/25 Steel reinforcement: B500C
---	--

Slab thickness h _c (m)	Span L(m)																		
	1.00	1.25	1.50	1.75	2.00	2.25	2.50	2.75	3.00	3.25	3.50	3.75	4.00	4.25	4.50	4.75	5.00	5.25	5.50
0.13	29.25	23.00	17.87	12.84	9.45	7.11	5.44	4.19	3.24	2.50	1.91	1.43	1.03	0.71					
0.14	31.27	24.79	20.07	14.31	10.53	7.92	6.06	4.67	3.63	2.79	2.13	1.59	1.16	0.79					
0.15	33.55	26.15	21.55	15.78	11.61	8.74	6.68	5.15	3.98	3.07	2.35	1.76	1.28	0.87	0.54				
0.16	35.41	27.79	22.82	17.25	12.69	9.55	7.31	5.63	4.35	3.36	2.57	1.93	1.40	0.96	0.59				
0.17	37.23	29.11	23.96	18.52	13.77	10.37	7.93	6.11	4.73	3.65	2.79	2.09	1.52	1.04	0.64				
0.18	39.02	30.70	25.18	19.98	14.85	11.18	8.56	6.59	5.10	3.93	3.01	2.26	1.64	1.12	0.69				
0.19	40.79	32.06	26.08	21.56	15.94	12.00	9.18	7.07	5.47	4.22	3.23	2.42	1.76	1.21	0.74				
0.20	42.52	33.55	27.19	22.75	17.02	12.81	9.80	7.56	5.85	4.51	3.45	2.59	1.88	1.29	0.80				

Maximum values of the variable load (kN/m²) , $\psi_2=0.60$

No additional reinforcement	1ø6	1ø8	1ø10	1ø12	1ø14
-----------------------------	-----	-----	------	------	------

FIRE RESISTANCE: 90 minutes

	Steel sheeting thickness: t=1.00 mm Concrete: C20/25 Steel reinforcement: B500C
---	--

Slab thickness h _c (m)	Span L(m)																		
	1.00	1.25	1.50	1.75	2.00	2.25	2.50	2.75	3.00	3.25	3.50	3.75	4.00	4.25	4.50	4.75	5.00	5.25	5.50
0.13	31.77	24.92	20.51	16.38	12.20	9.30	7.21	5.65	4.46	3.53	2.80	2.20	1.71	1.31	0.96	0.67			
0.14	33.98	26.89	22.01	18.17	13.60	10.37	8.03	6.30	4.97	3.94	3.12	2.46	1.91	1.46	1.08	0.75			
0.15	36.16	28.55	23.38	19.75	15.03	11.44	8.86	6.95	5.49	4.35	3.45	2.71	2.12	1.61	1.19	0.83	0.53		
0.16	38.19	29.98	24.73	20.70	16.32	12.50	9.68	7.60	6.00	4.76	3.77	2.97	2.32	1.76	1.31	0.92	0.58		
0.17	40.20	31.58	25.86	21.94	17.76	13.57	10.51	8.25	6.52	5.17	4.10	3.23	2.52	1.92	1.42	1.00	0.64		
0.18	42.38	33.46	27.28	22.86	19.04	14.63	11.34	8.90	7.03	5.58	4.42	3.48	2.72	2.07	1.54	1.08	0.69		
0.19	44.53	34.91	28.37	23.96	20.55	15.70	12.17	9.55	7.55	5.99	4.74	3.74	2.92	2.23	1.65	1.16	0.74		
0.20	46.45	36.44	29.74	24.95	21.32	16.73	13.00	10.20	8.06	6.39	5.07	4.00	3.12	2.38	1.77	1.24	0.80		

Maximum values of the variable load (kN/m²) , $\psi_2=0.60$

	Steel sheeting thickness: t=1.25 mm Concrete: C20/25 Steel reinforcement: B500C
---	--

Slab thickness h _c (m)	Span L(m)																		
	1.00	1.25	1.50	1.75	2.00	2.25	2.50	2.75	3.00	3.25	3.50	3.75	4.00	4.25	4.50	4.75	5.00	5.25	5.50
0.13	34.31	27.05	22.20	18.72	15.44	11.94	9.34	7.41	5.94	4.79	3.87	3.13	2.53	2.03	1.60	1.24	0.94	0.67	
0.14	36.90	29.01	23.88	20.02	17.27	13.31	10.41	8.26	6.62	5.35	4.32	3.50	2.83	2.27	1.80	1.39	1.05	0.76	0.51
0.15	39.06	30.75	25.35	21.47	18.39	14.59	11.48	9.11	7.31	5.90	4.77	3.87	3.12	2.51	1.99	1.55	1.17	0.84	0.57
0.16	41.68	32.77	26.89	22.62	19.49	15.89	12.56	9.97	8.00	6.45	5.23	4.23	3.42	2.75	2.18	1.70	1.28	0.93	0.62
0.17	43.88	34.36	28.28	23.85	20.47	17.26	13.64	10.82	8.68	7.01	5.68	4.60	3.72	2.99	2.37	1.85	1.40	1.01	0.68
0.18	45.94	34.12	29.51	24.95	21.44	18.77	14.67	11.60	9.37	7.56	6.13	4.97	4.02	3.22	2.56	2.00	1.52	1.10	0.74
0.19	47.97	37.96	30.99	26.05	22.40	19.56	15.64	12.50	10.05	8.12	6.58	5.33	4.31	3.46	2.75	2.15	1.63	1.18	0.80
0.20	49.87	39.58	32.25	27.20	23.13	20.30	16.79	13.35	10.70	8.67	7.03	5.70	4.61	3.70	2.94	2.30	1.75	1.27	0.86

Maximum values of the variable load (kN/m²) , $\psi_2=0.60$

No additional reinforcement	1ø6	1ø8	1ø10	1ø12	1ø14
-----------------------------	-----	-----	------	------	------

FIRE RESISTANCE: 120 minutes

	Steel sheeting thickness: t=0.75 mm Concrete: C20/25 Steel reinforcement: B500C
---	--

Slab thickness h _c (m)	Span L(m)																		
	1.00	1.25	1.50	1.75	2.00	2.25	2.50	2.75	3.00	3.25	3.50	3.75	4.00	4.25	4.50	4.75	5.00	5.25	5.50
0.13	28.72	22.61	16.95	12.06	8.85	6.64	5.06	3.88	2.98	2.28	1.72	1.26	0.89	0.58					
0.14	30.83	24.21	18.92	13.44	9.87	7.40	5.64	4.32	3.32	2.45	1.55	0.82	0.23						
0.15	32.82	25.72	20.86	14.82	10.88	8.17	6.22	4.77	3.66	2.66	1.67	0.88	0.23						
0.16	34.72	27.22	22.12	16.02	11.89	8.93	6.80	5.21	4.00	2.87	1.80	0.93	0.22						
0.17	36.55	28.71	23.26	17.58	12.90	9.69	7.37	5.66	4.35	3.08	1.92	0.99	0.22						
0.18	38.40	30.09	24.44	18.96	13.92	10.45	7.95	6.10	4.69	3.29	2.04	1.04	0.22						
0.19	40.13	31.43	25.54	20.13	14.93	11.21	8.53	6.55	5.03	3.50	2.17	1.09	0.21						
0.20	41.89	32.65	26.72	21.67	15.94	11.97	9.11	6.99	5.37	3.71	2.29	1.15	0.21						

Maximum values of the variable load (kN/m²) , $\psi_2=0.60$

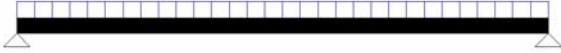
	Steel sheeting thickness: t=0.80 mm Concrete: C20/25 Steel reinforcement: B500C
---	--

Slab thickness h _c (m)	Span L(m)																		
	1.00	1.25	1.50	1.75	2.00	2.25	2.50	2.75	3.00	3.25	3.50	3.75	4.00	4.25	4.50	4.75	5.00	5.25	5.50
0.13	29.25	23.00	17.87	12.84	9.45	7.11	5.44	4.19	3.24	2.50	1.91	1.43	1.03	0.71					
0.14	31.27	24.79	20.07	14.31	10.53	7.92	6.06	4.67	3.63	2.52	1.61	0.87	0.27						
0.15	33.55	26.15	21.55	15.78	11.61	8.74	6.68	5.15	3.98	2.74	1.74	0.93	0.27						
0.16	35.41	27.79	22.82	17.25	12.69	9.55	7.31	5.63	4.33	2.96	1.87	1.00	0.28						
0.17	37.23	29.11	23.96	18.52	13.77	10.37	7.93	6.11	4.66	3.18	2.01	1.06	0.28						
0.18	39.02	30.70	25.18	19.98	14.85	11.18	8.56	6.59	4.99	3.40	2.14	1.12	0.29						
0.19	40.79	32.06	26.08	21.56	15.94	12.00	9.18	7.07	5.32	3.62	2.27	1.18	0.29						
0.20	42.52	33.55	27.19	22.75	17.02	12.81	9.80	7.56	5.65	3.84	2.40	1.24	0.29						

Maximum values of the variable load (kN/m²) , $\psi_2=0.60$

No additional reinforcement	1ø6	1ø8	1ø10	1ø12	1ø14
-----------------------------	-----	-----	------	------	------

FIRE RESISTANCE: 120 minutes

	Steel sheeting thickness: t=1.00 mm Concrete: C20/25 Steel reinforcement: B500C
---	--

Slab thickness h _c (m)	Span L(m)																		
	1.00	1.25	1.50	1.75	2.00	2.25	2.50	2.75	3.00	3.25	3.50	3.75	4.00	4.25	4.50	4.75	5.00	5.25	5.50
0.13	31.77	24.92	20.51	16.38	12.20	9.30	7.21	5.65	4.46	3.53	2.80	2.20	1.71	1.31	0.96	0.67			
0.14	33.98	26.89	22.01	18.17	13.60	10.37	7.80	5.73	4.15	2.93	1.96	1.17	0.53						
0.15	36.16	28.55	23.38	19.75	15.03	11.44	8.54	6.27	4.54	3.20	2.13	1.27	0.56						
0.16	38.19	29.98	24.73	20.70	16.32	12.50	9.28	6.81	4.93	3.47	2.30	1.37	0.60						
0.17	40.20	31.58	25.86	21.94	17.76	13.57	10.02	7.35	5.32	3.73	2.48	1.46	0.64						
0.18	42.38	33.46	27.28	22.86	19.04	14.63	10.77	7.89	5.70	4.00	2.65	1.56	0.67						
0.19	44.53	34.91	28.37	23.96	20.55	15.66	11.51	8.43	6.09	4.27	2.83	1.66	0.71						
0.20	46.45	36.44	29.74	24.95	21.32	16.68	12.25	8.97	6.48	4.54	3.00	1.76	0.74						

Maximum values of the variable load (kN/m²) , $\psi_2=0.60$

	Steel sheeting thickness: t=1.25 mm Concrete: C20/25 Steel reinforcement: B500C
---	--

Slab thickness h _c (m)	Span L(m)																		
	1.00	1.25	1.50	1.75	2.00	2.25	2.50	2.75	3.00	3.25	3.50	3.75	4.00	4.25	4.50	4.75	5.00	5.25	5.50
0.13	34.31	27.05	22.20	18.72	15.44	11.94	9.34	7.41	5.94	4.79	3.87	3.13	2.53	2.03	1.60	1.24	0.94	0.67	
0.14	36.90	29.01	23.88	20.02	16.86	12.66	9.65	7.43	5.74	4.42	2.37	1.53	0.84	0.27					
0.15	39.06	30.75	25.35	21.47	17.41	12.79	9.49	7.05	5.19	3.74	2.60	1.67	0.91	0.29					
0.16	41.68	32.77	26.89	22.62	18.95	13.92	10.33	7.67	5.65	4.07	2.82	1.81	0.99	0.30					
0.17	43.88	34.36	28.28	23.85	20.47	15.06	11.17	8.29	6.10	4.40	3.04	1.95	1.06	0.32					
0.18	45.94	34.12	29.51	24.95	21.44	16.19	12.01	8.91	6.56	4.72	3.27	2.10	1.14	0.34					
0.19	47.97	37.96	30.99	26.05	22.40	17.32	12.84	9.53	7.01	5.05	3.49	2.24	1.21	0.36					
0.20	49.87	39.58	32.25	27.20	23.13	18.46	13.68	10.15	7.47	5.37	3.72	2.38	1.28	0.37					

Maximum values of the variable load (kN/m²) , $\psi_2=0.60$

No additional reinforcement	1ø6	1ø8	1ø10	1ø12	1ø14
-----------------------------	-----	-----	------	------	------

FIRE RESISTANCE: 30 minutes

	Steel sheeting thickness: t=0.75 mm Concrete: C20/25 Steel reinforcement: B500C
---	--

Reinforcement at the positions of hogging moments

h _c (m)	0.13	0.14	0.15	0.16	0.17	0.18	0.19	0.20
reinforcement	Ø8/200	Ø8/200	Ø8/150	Ø8/150	Ø10/200	Ø10/200	Ø10/150	Ø10/150

Slab thickness h _c (m)	Span L(m)																			
	1.00	1.25	1.50	1.75	2.00	2.25	2.50	2.75	3.00	3.25	3.50	3.75	4.00	4.25	4.50	4.75	5.00	5.25	5.50	
0.13	22.58	17.67	14.36	10.43	7.58	5.63	4.22	3.18	2.38	1.76	1.26	0.86	0.53							
0.14	24.04	18.77	15.38	11.62	8.45	6.27	4.71	3.54	2.66	1.96	1.41	0.96	0.60							
0.15	25.74	20.05	16.28	12.70	9.32	6.92	5.19	3.91	2.93	2.17	1.56	1.07	0.66							
0.16	27.24	21.26	17.28	13.95	10.19	7.56	5.67	4.27	3.21	2.37	1.71	1.17	0.72							
0.17	28.70	22.34	18.14	15.05	11.06	8.21	6.16	4.64	3.48	2.57	1.85	1.27	0.79							
0.18	30.09	23.41	18.99	15.75	11.92	8.85	6.64	5.00	3.75	2.78	2.00	1.37	0.85							
0.19	31.46	24.46	19.83	16.53	12.79	9.50	7.13	5.37	4.03	2.98	2.15	1.47	0.92							
0.20	32.80	25.49	20.65	17.20	13.66	10.14	7.61	5.74	4.30	3.18	2.30	1.57	0.98							

Maximum values of the variable load (kN/m²) , $\psi_2=0.60$

	Steel sheeting thickness: t=0.80 mm Concrete: C20/25 Steel reinforcement: B500C
---	--

Reinforcement at the positions of hogging moments

h _c (m)	0.13	0.14	0.15	0.16	0.17	0.18	0.19	0.20
reinforcement	Ø8/200	Ø8/200	Ø8/150	Ø8/150	Ø10/200	Ø10/200	Ø10/150	Ø10/150

Slab thickness h _c (m)	Span L(m)																			
	1.00	1.25	1.50	1.75	2.00	2.25	2.50	2.75	3.00	3.25	3.50	3.75	4.00	4.25	4.50	4.75	5.00	5.25	5.50	
0.13	23.00	18.10	14.74	11.12	8.12	6.04	4.56	3.46	2.61	1.96	1.43	1.01	0.66							
0.14	24.79	19.35	15.75	12.29	9.04	6.74	5.08	3.85	2.92	2.18	1.60	1.13	0.74							
0.15	26.25	20.58	16.66	13.64	9.97	7.43	5.61	4.25	3.22	2.41	1.77	1.25	0.82							
0.16	27.89	21.78	17.54	14.77	10.90	8.12	6.09	4.65	3.52	2.64	1.94	1.37	0.90	0.52						
0.17	29.21	22.88	18.51	15.48	11.83	8.82	6.65	5.05	3.82	2.86	2.10	1.49	0.98	0.56						
0.18	30.60	23.93	19.46	16.28	12.73	9.51	7.18	5.45	4.12	3.09	2.27	1.60	1.06	0.60						
0.19	32.06	25.05	20.29	16.96	13.61	10.20	7.70	5.84	4.43	3.32	2.44	1.72	1.14	0.65						
0.20	33.56	26.11	21.11	17.63	14.57	10.89	8.23	6.24	4.73	3.54	2.60	1.84	1.22	0.70						

Maximum values of the variable load (kN/m²) , $\psi_2=0.60$

No additional reinforcement	1ø6	1ø8	1ø10	1ø12	1ø14
-----------------------------	-----	-----	------	------	------

FIRE RESISTANCE: 30 minutes

	Steel sheeting thickness: t=1.00 mm Concrete: C20/25 Steel reinforcement: B500C
---	--

Reinforcement at the positions of hogging moments

h _c (m)	0.13	0.14	0.15	0.16	0.17	0.18	0.19	0.20
reinforcement	Ø8/200	Ø8/200	Ø8/150	Ø8/150	Ø10/200	Ø10/200	Ø10/150	Ø10/150

Slab thickness h _c (m)	Span L(m)																		
	1.00	1.25	1.50	1.75	2.00	2.25	2.50	2.75	3.00	3.25	3.50	3.75	4.00	4.25	4.50	4.75	5.00	5.25	5.50
0.13	25.02	19.69	15.91	13.36	10.08	7.54	5.72	4.38	3.36	2.56	1.93	1.42	1.00	0.66					
0.14	26.89	21.03	17.02	14.31	11.25	8.46	6.43	4.92	3.78	2.89	2.18	1.61	1.14	0.76					
0.15	28.55	22.35	18.22	15.21	12.94	9.82	7.54	5.85	4.55	3.55	2.75	2.10	1.57	1.12	0.75				
0.16	30.28	23.55	19.25	16.16	13.75	10.69	8.25	6.39	4.98	3.88	3.01	2.30	1.72	1.23	0.83				
0.17	31.90	24.85	20.25	16.95	14.45	11.65	8.95	6.94	5.41	4.22	3.27	2.50	1.87	1.34	0.90	0.53			
0.18	33.25	26.00	21.25	17.66	15.15	12.48	9.66	7.49	5.84	4.55	3.52	2.70	2.01	1.45	0.97	0.57			
0.19	34.81	27.22	22.15	18.34	15.80	13.35	10.36	8.04	6.27	4.88	3.78	2.90	2.16	1.56	1.05	0.62			
0.20	36.34	28.44	23.10	19.10	16.43	14.20	10.95	8.59	6.69	5.22	4.04	3.10	2.31	1.67	1.12	0.66			

Maximum values of the variable load (kN/m²) , $\psi_2=0.60$

	Steel sheeting thickness: t=1.25 mm Concrete: C20/25 Steel reinforcement: B500C
---	--

Reinforcement at the positions of hogging moments

h _c (m)	0.13	0.14	0.15	0.16	0.17	0.18	0.19	0.20
reinforcement	Ø8/150	Ø8/150	Ø8/150	Ø8/150	Ø10/200	Ø10/200	Ø10/150	Ø10/150

Slab thickness h _c (m)	Span L(m)																		
	1.00	1.25	1.50	1.75	2.00	2.25	2.50	2.75	3.00	3.25	3.50	3.75	4.00	4.25	4.50	4.75	5.00	5.25	5.50
0.13	27.24	21.39	17.48	14.60	12.60	9.95	7.67	5.99	4.71	3.71	2.92	2.28	1.76	1.32	0.96				
0.14	29.10	22.89	18.70	15.71	13.46	11.20	8.69	6.79	5.34	4.22	3.33	2.61	2.02	1.53	1.12	0.77			
0.15	30.80	24.14	19.84	16.68	14.28	12.36	9.71	7.59	5.98	4.73	3.73	2.93	2.27	1.73	1.27	0.89	0.56		
0.16	32.57	25.73	20.91	17.59	15.05	13.10	10.70	8.39	6.62	5.24	4.14	3.26	2.53	1.93	1.43	1.00	0.64		
0.17	34.26	27.05	21.96	18.39	15.77	13.75	11.65	9.16	7.33	5.85	4.67	3.72	2.93	2.29	1.74	1.28	0.88	0.54	
0.18	35.95	28.15	23.15	19.27	16.55	14.25	12.55	9.92	7.91	6.31	5.04	4.01	3.17	2.47	1.88	1.38	0.96	0.59	
0.19	37.60	29.52	24.15	20.04	17.25	14.82	13.10	10.67	8.49	6.78	5.41	4.31	3.41	2.66	2.03	1.49	1.03	0.64	
0.20	39.28	30.78	25.00	20.90	17.98	15.55	13.55	11.40	9.05	7.24	5.79	4.61	3.64	2.84	2.17	1.60	1.11	0.69	

Maximum values of the variable load (kN/m²) , $\psi_2=0.60$

No additional reinforcement	1ø6	1ø8	1ø10	1ø12	1ø14
-----------------------------	-----	-----	------	------	------

FIRE RESISTANCE: 60 minutes

	Steel sheeting thickness: t=0.75 mm Concrete: C20/25 Steel reinforcement: B500C
---	--

Reinforcement at the positions of hogging moments

h _c (m)	0.13	0.14	0.15	0.16	0.17	0.18	0.19	0.20
reinforcement	Ø8/200	Ø8/200	Ø8/150	Ø8/150	Ø10/200	Ø10/200	Ø10/150	Ø10/150

Slab thickness h _c (m)	Span L(m)																			
	1.00	1.25	1.50	1.75	2.00	2.25	2.50	2.75	3.00	3.25	3.50	3.75	4.00	4.25	4.50	4.75	5.00	5.25	5.50	
0.13	22.58	17.67	14.36	10.43	7.58	5.63	4.22	3.18	2.38	1.76	1.26	0.86	0.53							
0.14	24.04	18.77	15.38	11.62	8.45	6.27	4.71	3.54	2.66	1.96	1.41	0.96	0.60							
0.15	25.74	20.05	16.28	12.70	9.32	6.92	5.19	3.91	2.93	2.17	1.56	1.07	0.66							
0.16	27.24	21.26	17.28	13.95	10.19	7.56	5.67	4.27	3.21	2.37	1.71	1.17	0.72							
0.17	28.70	22.34	18.14	15.05	11.06	8.21	6.16	4.64	3.48	2.57	1.85	1.27	0.79							
0.18	30.09	23.41	18.99	15.75	11.92	8.85	6.64	5.00	3.75	2.78	2.00	1.37	0.85							
0.19	31.46	24.46	19.83	16.53	12.79	9.50	7.13	5.37	4.03	2.98	2.15	1.47	0.92							
0.20	32.80	25.49	20.65	17.20	13.66	10.14	7.61	5.74	4.30	3.18	2.30	1.57	0.98							

Maximum values of the variable load (kN/m²) , $\psi_2=0.60$

	Steel sheeting thickness: t=0.80 mm Concrete: C20/25 Steel reinforcement: B500C
---	--

Reinforcement at the positions of hogging moments

h _c (m)	0.13	0.14	0.15	0.16	0.17	0.18	0.19	0.20
reinforcement	Ø8/200	Ø8/200	Ø8/150	Ø8/150	Ø10/200	Ø10/200	Ø10/150	Ø10/150

Slab thickness h _c (m)	Span L(m)																			
	1.00	1.25	1.50	1.75	2.00	2.25	2.50	2.75	3.00	3.25	3.50	3.75	4.00	4.25	4.50	4.75	5.00	5.25	5.50	
0.13	23.00	18.10	14.74	11.12	8.12	6.04	4.56	3.46	2.61	1.96	1.43	1.01	0.66							
0.14	24.79	19.35	15.75	12.29	9.04	6.74	5.08	3.85	2.92	2.18	1.60	1.13	0.74							
0.15	26.25	20.58	16.66	13.64	9.97	7.43	5.61	4.25	3.22	2.41	1.77	1.25	0.82							
0.16	27.89	21.78	17.54	14.77	10.90	8.12	6.09	4.65	3.52	2.64	1.94	1.37	0.90	0.52						
0.17	29.21	22.88	18.51	15.48	11.83	8.82	6.65	5.05	3.82	2.86	2.10	1.49	0.98	0.56						
0.18	30.60	23.93	19.46	16.28	12.73	9.51	7.18	5.45	4.12	3.09	2.27	1.60	1.06	0.60						
0.19	32.06	25.05	20.29	16.96	13.61	10.20	7.70	5.84	4.43	3.32	2.44	1.72	1.14	0.65						
0.20	33.56	26.11	21.11	17.63	14.57	10.89	8.23	6.24	4.73	3.54	2.60	1.84	1.22	0.70						

Maximum values of the variable load (kN/m²) , $\psi_2=0.60$

No additional reinforcement	1ø6	1ø8	1ø10	1ø12	1ø14
-----------------------------	-----	-----	------	------	------

FIRE RESISTANCE: 60 minutes

	Steel sheeting thickness: t=1.00 mm Concrete: C20/25 Steel reinforcement: B500C
---	--

Reinforcement at the positions of hogging moments

h _c (m)	0.13	0.14	0.15	0.16	0.17	0.18	0.19	0.20
reinforcement	Ø8/200	Ø8/200	Ø8/150	Ø8/150	Ø10/200	Ø10/200	Ø10/150	Ø10/150

Slab thickness h _c (m)	Span L(m)																		
	1.00	1.25	1.50	1.75	2.00	2.25	2.50	2.75	3.00	3.25	3.50	3.75	4.00	4.25	4.50	4.75	5.00	5.25	5.50
0.13	25.02	19.69	15.91	13.36	10.08	7.54	5.72	4.38	3.36	2.56	1.93	1.42	1.00	0.66					
0.14	26.89	21.03	17.02	14.31	11.25	8.46	6.43	4.92	3.78	2.89	2.18	1.61	1.14	0.76					
0.15	28.55	22.35	18.22	15.21	12.94	9.82	7.54	5.85	4.55	3.55	2.75	2.10	1.57	1.12	0.75				
0.16	30.28	23.55	19.25	16.16	13.75	10.69	8.25	6.39	4.98	3.88	3.01	2.30	1.72	1.23	0.83				
0.17	31.90	24.85	20.25	16.95	14.45	11.65	8.95	6.94	5.41	4.22	3.27	2.50	1.87	1.34	0.90	0.53			
0.18	33.25	26.00	21.25	17.66	15.15	12.48	9.66	7.49	5.84	4.55	3.52	2.70	2.01	1.45	0.97	0.57			
0.19	34.81	27.22	22.15	18.34	15.80	13.35	10.36	8.04	6.27	4.88	3.78	2.90	2.16	1.56	1.05	0.62			
0.20	36.34	28.44	23.10	19.10	16.43	14.20	10.95	8.59	6.69	5.22	4.04	3.10	2.31	1.67	1.12	0.66			

Maximum values of the variable load (kN/m²) , $\psi_2=0.60$

	Steel sheeting thickness: t=1.25 mm Concrete: C20/25 Steel reinforcement: B500C
---	--

Reinforcement at the positions of hogging moments

h _c (m)	0.13	0.14	0.15	0.16	0.17	0.18	0.19	0.20
reinforcement	Ø8/150	Ø8/150	Ø8/150	Ø8/150	Ø10/200	Ø10/200	Ø10/150	Ø10/150

Slab thickness h _c (m)	Span L(m)																		
	1.00	1.25	1.50	1.75	2.00	2.25	2.50	2.75	3.00	3.25	3.50	3.75	4.00	4.25	4.50	4.75	5.00	5.25	5.50
0.13	27.24	21.39	17.48	14.60	12.60	9.95	7.67	5.99	4.71	3.71	2.92	2.28	1.76	1.32	0.96				
0.14	29.10	22.89	18.70	15.71	13.46	11.20	8.69	6.79	5.34	4.22	3.33	2.61	2.02	1.53	1.12	0.77			
0.15	30.80	24.14	19.84	16.68	14.28	12.36	9.71	7.59	5.98	4.73	3.73	2.93	2.27	1.73	1.27	0.89	0.56		
0.16	32.57	25.73	20.91	17.59	15.05	13.10	10.70	8.39	6.62	5.24	4.14	3.26	2.53	1.93	1.43	1.00	0.64		
0.17	34.26	27.05	21.96	18.39	15.77	13.75	11.65	9.16	7.33	5.85	4.67	3.72	2.93	2.29	1.74	1.28	0.88	0.54	
0.18	35.95	28.15	23.15	19.27	16.55	14.25	12.55	9.92	7.91	6.31	5.04	4.01	3.17	2.47	1.88	1.38	0.96	0.59	
0.19	37.60	29.52	24.15	20.04	17.25	14.82	13.10	10.67	8.49	6.78	5.41	4.31	3.41	2.66	2.03	1.49	1.03	0.64	
0.20	39.28	30.78	25.00	20.90	17.98	15.55	13.55	11.40	9.05	7.24	5.79	4.61	3.64	2.84	2.17	1.60	1.11	0.69	

Maximum values of the variable load (kN/m²) , $\psi_2=0.60$

No additional reinforcement	1ø6	1ø8	1ø10	1ø12	1ø14
-----------------------------	-----	-----	------	------	------

FIRE RESISTANCE: 90 minutes

	Steel sheeting thickness: t=0.75 mm Concrete: C20/25 Steel reinforcement: B500C
---	--

Reinforcement at the positions of hogging moments

h _c (m)	0.13	0.14	0.15	0.16	0.17	0.18	0.19	0.20
reinforcement	Ø8/200	Ø8/200	Ø8/150	Ø8/150	Ø10/200	Ø10/200	Ø10/150	Ø10/150

Slab thickness h _c (m)	Span L(m)																		
	1.00	1.25	1.50	1.75	2.00	2.25	2.50	2.75	3.00	3.25	3.50	3.75	4.00	4.25	4.50	4.75	5.00	5.25	5.50
0.13	22.58	17.67	14.36	10.43	7.58	5.63	4.22	3.18	2.38	1.76	1.26	0.86	0.53						
0.14	24.04	18.77	15.38	11.62	8.45	6.27	4.71	3.54	2.66	1.96	1.41	0.96	0.60						
0.15	25.74	20.05	16.28	12.70	9.32	6.92	5.19	3.91	2.93	2.17	1.56	1.07	0.66						
0.16	27.24	21.26	17.28	13.95	10.19	7.56	5.67	4.27	3.21	2.37	1.71	1.17	0.72						
0.17	28.70	22.34	18.14	15.05	11.06	8.21	6.16	4.64	3.48	2.57	1.85	1.27	0.79						
0.18	30.09	23.41	18.99	15.75	11.92	8.85	6.64	5.00	3.75	2.78	2.00	1.37	0.85						
0.19	31.46	24.46	19.83	16.53	12.79	9.50	7.13	5.37	4.03	2.98	2.15	1.47	0.92						
0.20	32.80	25.49	20.65	17.20	13.66	10.14	7.61	5.74	4.30	3.18	2.30	1.57	0.98						

Maximum values of the variable load (kN/m²) , $\psi_2=0.60$

	Steel sheeting thickness: t=0.80 mm Concrete: C20/25 Steel reinforcement: B500C
---	--

Reinforcement at the positions of hogging moments

h _c (m)	0.13	0.14	0.15	0.16	0.17	0.18	0.19	0.20
reinforcement	Ø8/200	Ø8/200	Ø8/150	Ø8/150	Ø10/200	Ø10/200	Ø10/150	Ø10/150

Slab thickness h _c (m)	Span L(m)																		
	1.00	1.25	1.50	1.75	2.00	2.25	2.50	2.75	3.00	3.25	3.50	3.75	4.00	4.25	4.50	4.75	5.00	5.25	5.50
0.13	23.00	18.10	14.74	11.12	8.12	6.04	4.56	3.46	2.61	1.96	1.43	1.01	0.66						
0.14	24.79	19.35	15.75	12.29	9.04	6.74	5.08	3.85	2.92	2.18	1.60	1.13	0.74						
0.15	26.25	20.58	16.66	13.64	9.97	7.43	5.61	4.25	3.22	2.41	1.77	1.25	0.82						
0.16	27.89	21.78	17.54	14.77	10.90	8.12	6.09	4.65	3.52	2.64	1.94	1.37	0.90	0.52					
0.17	29.21	22.88	18.51	15.48	11.83	8.82	6.65	5.05	3.82	2.86	2.10	1.49	0.98	0.56					
0.18	30.60	23.93	19.46	16.28	12.73	9.51	7.18	5.45	4.12	3.09	2.27	1.60	1.06	0.60					
0.19	32.06	25.05	20.29	16.96	13.61	10.20	7.70	5.84	4.43	3.32	2.44	1.72	1.14	0.65					
0.20	33.56	26.11	21.11	17.63	14.57	10.89	8.23	6.24	4.73	3.54	2.60	1.84	1.22	0.70					

Maximum values of the variable load (kN/m²) , $\psi_2=0.60$

No additional reinforcement	1ø6	1ø8	1ø10	1ø12	1ø14
-----------------------------	-----	-----	------	------	------

FIRE RESISTANCE: 90 minutes

	Steel sheeting thickness: t=1.00 mm Concrete: C20/25 Steel reinforcement: B500C
---	--

Reinforcement at the positions of hogging moments

h _c (m)	0.13	0.14	0.15	0.16	0.17	0.18	0.19	0.20
reinforcement	Ø8/200	Ø8/200	Ø8/150	Ø8/150	Ø10/200	Ø10/200	Ø10/150	Ø10/150

Slab thickness	Span L(m)																			
	h _c (m)	1.00	1.25	1.50	1.75	2.00	2.25	2.50	2.75	3.00	3.25	3.50	3.75	4.00	4.25	4.50	4.75	5.00	5.25	5.50
0.13	25.02	19.69	15.91	13.36	10.08	7.54	5.72	4.38	3.36	2.56	1.93	1.42	1.00	0.66						
0.14	26.89	21.03	17.02	14.31	11.25	8.46	6.43	4.92	3.78	2.89	2.18	1.61	1.14	0.76						
0.15	28.55	22.35	18.22	15.21	12.94	9.82	7.54	5.85	4.55	3.55	2.75	2.10	1.57	1.12	0.75					
0.16	30.28	23.55	19.25	16.16	13.75	10.69	8.25	6.39	4.98	3.88	3.01	2.30	1.72	1.23	0.83					
0.17	31.90	24.85	20.25	16.95	14.45	11.65	8.95	6.94	5.41	4.22	3.27	2.50	1.87	1.34	0.90	0.53				
0.18	33.25	26.00	21.25	17.66	15.15	12.48	9.66	7.49	5.84	4.55	3.52	2.70	2.01	1.45	0.97	0.57				
0.19	34.81	27.22	22.15	18.34	15.80	13.35	10.36	8.04	6.27	4.88	3.78	2.90	2.16	1.56	1.05	0.62				
0.20	36.34	28.44	23.10	19.10	16.43	14.20	10.95	8.59	6.69	5.22	4.04	3.10	2.31	1.67	1.12	0.66				

Maximum values of the variable load (kN/m²) , $\psi_2=0.60$

	Steel sheeting thickness: t=1.25 mm Concrete: C20/25 Steel reinforcement: B500C
---	--

Reinforcement at the positions of hogging moments

h _c (m)	0.13	0.14	0.15	0.16	0.17	0.18	0.19	0.20
reinforcement	Ø8/150	Ø8/150	Ø8/150	Ø8/150	Ø10/200	Ø10/200	Ø10/150	Ø10/150

Slab thickness	Span L(m)																			
	h _c (m)	1.00	1.25	1.50	1.75	2.00	2.25	2.50	2.75	3.00	3.25	3.50	3.75	4.00	4.25	4.50	4.75	5.00	5.25	5.50
0.13	27.24	21.39	17.48	14.60	12.60	9.95	7.67	5.99	4.71	3.71	2.92	2.28	1.76	1.32	0.96					
0.14	29.10	22.89	18.70	15.71	13.46	11.20	8.69	6.79	5.34	4.22	3.33	2.61	2.02	1.53	1.12	0.77				
0.15	30.80	24.14	19.84	16.68	14.28	12.36	9.71	7.59	5.98	4.73	3.73	2.93	2.27	1.73	1.27	0.89	0.56			
0.16	32.57	25.73	20.91	17.59	15.05	13.10	10.70	8.39	6.62	5.24	4.14	3.26	2.53	1.93	1.43	1.00	0.64			
0.17	34.26	27.05	21.96	18.39	15.77	13.75	11.65	9.16	7.33	5.85	4.67	3.72	2.93	2.29	1.74	1.28	0.88	0.54		
0.18	35.95	28.15	23.15	19.27	16.55	14.25	12.55	9.92	7.91	6.31	5.04	4.01	3.17	2.47	1.88	1.38	0.96	0.59		
0.19	37.60	29.52	24.15	20.04	17.25	14.82	13.10	10.67	8.49	6.78	5.41	4.31	3.41	2.66	2.03	1.49	1.03	0.64		
0.20	39.28	30.78	25.00	20.90	17.98	15.55	13.55	11.40	9.05	7.24	5.79	4.61	3.64	2.84	2.17	1.60	1.11	0.69		

Maximum values of the variable load (kN/m²) , $\psi_2=0.60$

No additional reinforcement	1ø6	1ø8	1ø10	1ø12	1ø14
-----------------------------	-----	-----	------	------	------

FIRE RESISTANCE: 120 minutes

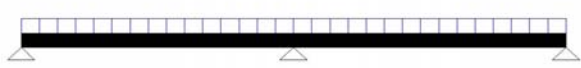
	Steel sheeting thickness: t=0.75 mm Concrete: C20/25 Steel reinforcement: B500C
---	--

Reinforcement at the positions of hogging moments

h _c (m)	0.13	0.14	0.15	0.16	0.17	0.18	0.19	0.20
reinforcement	Ø8/200	Ø8/200	Ø8/150	Ø8/150	Ø10/200	Ø10/200	Ø10/150	Ø10/150

Slab thickness h _c (m)	Span L(m)																		
	1.00	1.25	1.50	1.75	2.00	2.25	2.50	2.75	3.00	3.25	3.50	3.75	4.00	4.25	4.50	4.75	5.00	5.25	5.50
0.13	22.58	17.67	14.36	10.43	7.58	5.63	4.22	3.18	2.38	1.76	1.26	0.86	0.53						
0.14	24.04	18.77	15.38	11.62	8.45	6.27	4.71	3.54	2.66	1.96	1.41	0.96	0.60						
0.15	25.74	20.05	16.28	12.70	9.32	6.92	5.19	3.91	2.93	2.17	1.56	1.07	0.66						
0.16	27.24	21.26	17.28	13.95	10.19	7.56	5.67	4.27	3.21	2.37	1.71	1.17	0.72						
0.17	28.70	22.34	18.14	15.05	11.06	8.21	6.16	4.64	3.48	2.57	1.85	1.27	0.79						
0.18	30.09	23.41	18.99	15.75	11.92	8.85	6.64	5.00	3.75	2.78	2.00	1.37	0.85						
0.19	31.46	24.46	19.83	16.53	12.79	9.50	7.13	5.37	4.03	2.98	2.15	1.47	0.92						
0.20	32.80	25.49	20.65	17.20	13.66	10.14	7.61	5.74	4.30	3.18	2.30	1.57	0.98						

Maximum values of the variable load (kN/m²) , $\psi_2=0.60$

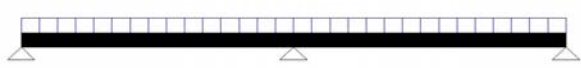
	Steel sheeting thickness: t=0.80 mm Concrete: C20/25 Steel reinforcement: B500C
---	--

Reinforcement at the positions of hogging moments

h _c (m)	0.13	0.14	0.15	0.16	0.17	0.18	0.19	0.20
reinforcement	Ø8/200	Ø8/200	Ø8/150	Ø8/150	Ø10/200	Ø10/200	Ø10/150	Ø10/150

Slab thickness h _c (m)	Span L(m)																		
	1.00	1.25	1.50	1.75	2.00	2.25	2.50	2.75	3.00	3.25	3.50	3.75	4.00	4.25	4.50	4.75	5.00	5.25	5.50
0.13	23.00	18.10	14.74	11.12	8.12	6.04	4.56	3.46	2.61	1.96	1.43	1.01	0.66						
0.14	24.79	19.35	15.75	12.29	9.04	6.74	5.08	3.85	2.92	2.18	1.60	1.13	0.74						
0.15	26.25	20.58	16.66	13.64	9.97	7.43	5.61	4.25	3.22	2.41	1.77	1.25	0.82						
0.16	27.89	21.78	17.54	14.77	10.90	8.12	6.09	4.65	3.52	2.64	1.94	1.37	0.90	0.52					
0.17	29.21	22.88	18.51	15.48	11.83	8.82	6.65	5.05	3.82	2.86	2.10	1.49	0.98	0.56					
0.18	30.60	23.93	19.46	16.28	12.73	9.51	7.18	5.45	4.12	3.09	2.27	1.60	1.06	0.60					
0.19	32.06	25.05	20.29	16.96	13.61	10.20	7.70	5.84	4.43	3.32	2.44	1.72	1.14	0.65					
0.20	33.56	26.11	21.11	17.63	14.57	10.89	8.23	6.24	4.73	3.54	2.60	1.84	1.22	0.70					

Maximum values of the variable load (kN/m²) , $\psi_2=0.60$

No additional reinforcement	1ø6	1ø8	1ø10	1ø12	1ø14
-----------------------------	-----	-----	------	------	------

FIRE RESISTANCE: 120 minutes

	Steel sheeting thickness: t=1.00 mm Concrete: C20/25 Steel reinforcement: B500C
---	--

Reinforcement at the positions of hogging moments

h _c (m)	0.13	0.14	0.15	0.16	0.17	0.18	0.19	0.20
reinforcement	Ø8/200	Ø8/200	Ø8/150	Ø8/150	Ø10/200	Ø10/200	Ø10/150	Ø10/150

Slab thickness h _c (m)	Span L(m)																		
	1.00	1.25	1.50	1.75	2.00	2.25	2.50	2.75	3.00	3.25	3.50	3.75	4.00	4.25	4.50	4.75	5.00	5.25	5.50
0.13	25.02	19.69	15.91	13.36	10.08	7.54	5.72	4.38	3.36	2.56	1.93	1.42	1.00	0.66					
0.14	26.89	21.03	17.02	14.31	11.25	8.46	6.43	4.92	3.78	2.89	2.18	1.61	1.14	0.76					
0.15	28.55	22.35	18.22	15.21	12.94	9.82	7.54	5.85	4.55	3.55	2.75	2.10	1.57	1.12	0.75				
0.16	30.28	23.55	19.25	16.16	13.75	10.69	8.25	6.39	4.98	3.88	3.01	2.30	1.72	1.23	0.83				
0.17	31.90	24.85	20.25	16.95	14.45	11.65	8.95	6.94	5.41	4.22	3.27	2.50	1.87	1.34	0.90	0.53			
0.18	33.25	26.00	21.25	17.66	15.15	12.48	9.66	7.49	5.84	4.55	3.52	2.70	2.01	1.45	0.97	0.57			
0.19	34.81	27.22	22.15	18.34	15.80	13.35	10.36	8.04	6.27	4.88	3.78	2.90	2.16	1.56	1.05	0.62			
0.20	36.34	28.44	23.10	19.10	16.43	14.20	10.95	8.59	6.69	5.22	4.04	3.10	2.31	1.67	1.12	0.66			

Maximum values of the variable load (kN/m²) , $\psi_2=0.60$

	Steel sheeting thickness: t=1.25 mm Concrete: C20/25 Steel reinforcement: B500C
---	--

Reinforcement at the positions of hogging moments

h _c (m)	0.13	0.14	0.15	0.16	0.17	0.18	0.19	0.20
reinforcement	Ø8/150	Ø8/150	Ø8/150	Ø8/150	Ø10/200	Ø10/200	Ø10/150	Ø10/150

Slab thickness h _c (m)	Span L(m)																		
	1.00	1.25	1.50	1.75	2.00	2.25	2.50	2.75	3.00	3.25	3.50	3.75	4.00	4.25	4.50	4.75	5.00	5.25	5.50
0.13	27.24	21.39	17.48	14.60	12.60	9.95	7.67	5.99	4.71	3.71	2.92	2.28	1.76	1.32	0.96				
0.14	29.10	22.89	18.70	15.71	13.46	11.20	8.69	6.79	5.34	4.22	3.33	2.61	2.02	1.53	1.12	0.77			
0.15	30.80	24.14	19.84	16.68	14.28	12.36	9.71	7.59	5.98	4.73	3.73	2.93	2.27	1.73	1.27	0.89	0.56		
0.16	32.57	25.73	20.91	17.59	15.05	13.10	10.70	8.39	6.62	5.24	4.14	3.26	2.53	1.93	1.43	1.00	0.64		
0.17	34.26	27.05	21.96	18.39	15.77	13.75	11.65	9.16	7.33	5.85	4.67	3.72	2.93	2.29	1.74	1.28	0.88	0.54	
0.18	35.95	28.15	23.15	19.27	16.55	14.25	12.55	9.92	7.91	6.31	5.04	4.01	3.17	2.47	1.88	1.38	0.96	0.59	
0.19	37.60	29.52	24.15	20.04	17.25	14.82	13.10	10.67	8.49	6.78	5.41	4.31	3.41	2.66	2.03	1.49	1.03	0.64	
0.20	39.28	30.78	25.00	20.90	17.98	15.55	13.55	11.40	9.05	7.24	5.79	4.61	3.64	2.84	2.17	1.60	1.11	0.69	

Maximum values of the variable load (kN/m²) , $\psi_2=0.60$

No additional reinforcement	1ø6	1ø8	1ø10	1ø12	1ø14
-----------------------------	-----	-----	------	------	------

FIRE RESISTANCE: 30 minutes

	Steel sheeting thickness: t=0.75 mm Concrete: C20/25 Steel reinforcement: B500C
---	--

Reinforcement at the positions of hogging moments

h _c (m)	0.13	0.14	0.15	0.16	0.17	0.18	0.19	0.20
reinforcement	Ø8/200	Ø8/200	Ø8/150	Ø8/150	Ø10/200	Ø10/200	Ø10/150	Ø10/150

Slab thickness h _c (m)	Span L(m)																		
	1.00	1.25	1.50	1.75	2.00	2.25	2.50	2.75	3.00	3.25	3.50	3.75	4.00	4.25	4.50	4.75	5.00	5.25	5.50
0.13	27.24	21.39	17.48	14.60	12.60	9.95	7.67	5.99	4.71	3.71	2.92	2.28	1.76	1.32	0.96				
0.14	29.10	22.89	18.70	15.71	13.46	11.20	8.69	6.79	5.34	4.22	3.33	2.61	2.02	1.53	1.12	0.77			
0.15	30.80	24.14	19.84	16.68	14.28	12.36	9.71	7.59	5.98	4.73	3.73	2.93	2.27	1.73	1.27	0.89	0.56		
0.16	32.57	25.73	20.91	17.59	15.05	13.10	10.70	8.39	6.62	5.24	4.14	3.26	2.53	1.93	1.43	1.00	0.64		
0.17	34.26	27.05	21.96	18.39	15.77	13.75	11.65	9.16	7.33	5.85	4.67	3.72	2.93	2.29	1.74	1.28	0.88	0.54	
0.18	35.95	28.15	23.15	19.27	16.55	14.25	12.55	9.92	7.91	6.31	5.04	4.01	3.17	2.47	1.88	1.38	0.96	0.59	
0.19	37.60	29.52	24.15	20.04	17.25	14.82	13.10	10.67	8.49	6.78	5.41	4.31	3.41	2.66	2.03	1.49	1.03	0.64	
0.20	39.28	30.78	25.00	20.90	17.98	15.55	13.55	11.40	9.05	7.24	5.79	4.61	3.64	2.84	2.17	1.60	1.11	0.69	

Maximum values of the variable load (kN/m²), ψ₂=0.60

	Steel sheeting thickness: t=0.80 mm Concrete: C20/25 Steel reinforcement: B500C
---	--

Reinforcement at the positions of hogging moments

h _c (m)	0.13	0.14	0.15	0.16	0.17	0.18	0.19	0.20
reinforcement	Ø8/200	Ø8/200	Ø8/150	Ø8/150	Ø10/200	Ø10/200	Ø10/150	Ø10/150

Slab thickness h _c (m)	Span L(m)																		
	1.00	1.25	1.50	1.75	2.00	2.25	2.50	2.75	3.00	3.25	3.50	3.75	4.00	4.25	4.50	4.75	5.00	5.25	5.50
0.13	24.06	18.97	15.40	11.67	8.54	6.38	4.83	3.68	2.81	2.12	1.58	1.14	0.77						
0.14	25.82	20.17	16.55	12.95	9.51	7.11	5.39	4.11	3.13	2.37	1.76	1.27	0.87	0.53					
0.15	27.55	21.55	17.55	14.30	10.49	7.84	5.94	4.53	3.45	2.61	1.94	1.40	0.96	0.59					
0.16	29.16	22.72	18.50	15.55	11.47	8.57	6.50	4.95	3.78	2.86	2.13	1.54	1.05	0.64					
0.17	30.64	23.86	19.45	16.30	12.45	9.31	7.05	5.38	4.10	3.10	2.31	1.67	1.14	0.70					
0.18	32.10	25.08	20.40	17.10	13.40	10.04	7.61	5.80	4.43	3.35	2.49	1.80	1.23	0.76					
0.19	33.63	26.28	21.35	17.80	14.35	10.77	8.16	6.23	4.75	3.60	2.68	1.93	1.32	0.82					
0.20	35.14	27.36	22.20	18.45	15.35	11.50	8.72	6.65	5.07	3.84	2.86	2.07	1.42	0.87					

Maximum values of the variable load (kN/m²), ψ₂=0.60

No additional reinforcement	1ø6	1ø8	1ø10	1ø12	1ø14
-----------------------------	-----	-----	------	------	------

FIRE RESISTANCE: 30 minutes

	Steel sheeting thickness: t=1.00 mm Concrete: C20/25 Steel reinforcement: B500C
---	--

Reinforcement at the positions of hogging moments

h_c (m)	0.13	0.14	0.15	0.16	0.17	0.18	0.19	0.20
reinforcement	Ø8/200	Ø8/200	Ø8/150	Ø8/150	Ø10/200	Ø10/200	Ø10/150	Ø10/150

Slab thickness h_c (m)	Span L(m)																		
	1.00	1.25	1.50	1.75	2.00	2.25	2.50	2.75	3.00	3.25	3.50	3.75	4.00	4.25	4.50	4.75	5.00	5.25	5.50
0.13	26.24	20.51	16.80	14.12	11.02	8.40	6.47	5.03	3.94	3.08	2.40	1.85	1.40	1.03	0.71				
0.14	28.09	21.98	18.00	15.10	12.35	9.37	7.21	5.61	4.39	3.44	2.68	2.07	1.57	1.15	0.80	0.50			
0.15	29.91	23.45	19.05	16.05	13.53	10.33	7.96	6.19	4.85	3.80	2.96	2.29	1.73	1.27	0.89	0.56			
0.16	31.51	24.63	20.15	16.95	14.46	11.30	8.70	6.77	5.30	4.16	3.24	2.50	1.90	1.40	0.97	0.61			
0.17	33.28	25.96	21.25	17.70	15.20	12.25	9.45	7.35	5.76	4.51	3.52	2.72	2.06	1.52	1.06	0.67			
0.18	34.93	27.18	22.25	18.60	15.90	13.09	10.19	7.93	6.21	4.87	3.80	2.94	2.23	1.64	1.15	0.73			
0.19	36.25	28.57	23.15	19.45	16.59	14.05	10.95	8.51	6.67	5.23	4.08	3.16	2.40	1.76	1.23	0.78			
0.20	37.94	29.74	24.05	20.22	17.18	14.94	11.65	9.09	7.12	5.59	4.36	3.37	2.56	1.89	1.32	0.84			

Maximum values of the variable load (kN/m²) , $\psi_2=0.60$

	Steel sheeting thickness: t=1.25 mm Concrete: C20/25 Steel reinforcement: B500C
--	--

Reinforcement at the positions of hogging moments

h_c (m)	0.13	0.14	0.15	0.16	0.17	0.18	0.19	0.20
reinforcement	Ø8/150	Ø8/150	Ø8/150	Ø8/150	Ø10/200	Ø10/200	Ø10/150	Ø10/150

Slab thickness h_c (m)	Span L(m)																		
	1.00	1.25	1.50	1.75	2.00	2.25	2.50	2.75	3.00	3.25	3.50	3.75	4.00	4.25	4.50	4.75	5.00	5.25	5.50
0.13	28.46	22.36	18.29	15.39	13.20	10.85	8.45	6.65	5.30	4.25	3.40	2.72	2.15	1.70	1.31	0.98	0.70		
0.14	30.48	23.93	19.58	16.46	14.10	12.10	9.41	7.43	5.92	4.74	3.80	3.02	2.42	1.90	1.47	1.10	0.78		
0.15	32.45	25.45	20.67	17.45	14.95	12.95	10.32	8.20	6.53	5.23	4.20	3.36	2.67	2.10	1.62	1.21	0.87	0.57	
0.16	34.08	26.90	21.89	18.40	15.80	13.75	11.35	8.97	7.14	5.72	4.59	3.67	2.92	2.30	1.78	1.33	0.95	0.63	
0.17	35.84	28.25	23.08	19.25	16.50	14.45	12.30	9.67	7.76	6.21	4.99	4.00	3.18	2.50	1.94	1.45	1.04	0.69	
0.18	37.67	29.70	24.25	20.30	17.25	15.10	13.25	10.45	8.37	6.71	5.38	4.31	3.43	2.71	2.09	1.57	1.13	0.75	
0.19	39.36	30.95	25.30	21.20	18.00	15.65	13.80	11.25	8.99	7.20	5.78	4.63	3.69	2.91	2.25	1.69	1.22	0.81	
0.20	40.96	32.22	26.27	22.10	18.88	16.20	14.25	12.02	9.57	7.69	6.18	4.95	3.95	3.11	2.41	1.81	1.30	0.87	

Maximum values of the variable load (kN/m²) , $\psi_2=0.60$

No additional reinforcement	1ø6	1ø8	1ø10	1ø12	1ø14
-----------------------------	-----	-----	------	------	------

FIRE RESISTANCE: 60 minutes

	Steel sheeting thickness: t=0.75 mm Concrete: C20/25 Steel reinforcement: B500C
---	--

Reinforcement at the positions of hogging moments

h _c (m)	0.13	0.14	0.15	0.16	0.17	0.18	0.19	0.20
reinforcement	Ø8/200	Ø8/200	Ø8/150	Ø8/150	Ø10/200	Ø10/200	Ø10/150	Ø10/150

Slab thickness h _c (m)	Span L(m)																		
	1.00	1.25	1.50	1.75	2.00	2.25	2.50	2.75	3.00	3.25	3.50	3.75	4.00	4.25	4.50	4.75	5.00	5.25	5.50
0.13	27.24	21.39	17.48	14.60	12.60	9.95	7.67	5.99	4.71	3.71	2.92	2.28	1.76	1.32	0.96				
0.14	29.10	22.89	18.70	15.71	13.46	11.20	8.69	6.79	5.34	4.22	3.33	2.61	2.02	1.53	1.12	0.77			
0.15	30.80	24.14	19.84	16.68	14.28	12.36	9.71	7.59	5.98	4.73	3.73	2.93	2.27	1.73	1.27	0.89	0.56		
0.16	32.57	25.73	20.91	17.59	15.05	13.10	10.70	8.39	6.62	5.24	4.14	3.26	2.53	1.93	1.43	1.00	0.64		
0.17	34.26	27.05	21.96	18.39	15.77	13.75	11.65	9.16	7.33	5.85	4.67	3.72	2.93	2.29	1.74	1.28	0.88	0.54	
0.18	35.95	28.15	23.15	19.27	16.55	14.25	12.55	9.92	7.91	6.31	5.04	4.01	3.17	2.47	1.88	1.38	0.96	0.59	
0.19	37.60	29.52	24.15	20.04	17.25	14.82	13.10	10.67	8.49	6.78	5.41	4.31	3.41	2.66	2.03	1.49	1.03	0.64	
0.20	39.28	30.78	25.00	20.90	17.98	15.55	13.55	11.40	9.05	7.24	5.79	4.61	3.64	2.84	2.17	1.60	1.11	0.69	

Maximum values of the variable load (kN/m²), $\psi_2=0.60$

	Steel sheeting thickness: t=0.80 mm Concrete: C20/25 Steel reinforcement: B500C
---	--

Reinforcement at the positions of hogging moments

h _c (m)	0.13	0.14	0.15	0.16	0.17	0.18	0.19	0.20
reinforcement	Ø8/200	Ø8/200	Ø8/150	Ø8/150	Ø10/200	Ø10/200	Ø10/150	Ø10/150

Slab thickness h _c (m)	Span L(m)																		
	1.00	1.25	1.50	1.75	2.00	2.25	2.50	2.75	3.00	3.25	3.50	3.75	4.00	4.25	4.50	4.75	5.00	5.25	5.50
0.13	24.06	18.97	15.40	11.67	8.54	6.38	4.83	3.68	2.81	2.12	1.58	1.14	0.77						
0.14	25.82	20.17	16.55	12.95	9.51	7.11	5.39	4.11	3.13	2.37	1.76	1.27	0.87	0.53					
0.15	27.55	21.55	17.55	14.30	10.49	7.84	5.94	4.53	3.45	2.61	1.94	1.40	0.96	0.59					
0.16	29.16	22.72	18.50	15.55	11.47	8.57	6.50	4.95	3.78	2.86	2.13	1.54	1.05	0.64					
0.17	30.64	23.86	19.45	16.30	12.45	9.31	7.05	5.38	4.10	3.10	2.31	1.67	1.14	0.70					
0.18	32.10	25.08	20.40	17.10	13.40	10.04	7.61	5.80	4.43	3.35	2.49	1.80	1.23	0.76					
0.19	33.63	26.28	21.35	17.80	14.35	10.77	8.16	6.23	4.75	3.60	2.68	1.93	1.32	0.82					
0.20	35.14	27.36	22.20	18.45	15.35	11.50	8.72	6.65	5.07	3.84	2.86	2.07	1.42	0.87					

Maximum values of the variable load (kN/m²), $\psi_2=0.60$

No additional reinforcement	1ø6	1ø8	1ø10	1ø12	1ø14
-----------------------------	-----	-----	------	------	------

FIRE RESISTANCE: 60 minutes

	Steel sheeting thickness: t=1.00 mm Concrete: C20/25 Steel reinforcement: B500C
---	--

Reinforcement at the positions of hogging moments

h_c (m)	0.13	0.14	0.15	0.16	0.17	0.18	0.19	0.20
reinforcement	Ø8/200	Ø8/200	Ø8/150	Ø8/150	Ø10/200	Ø10/200	Ø10/150	Ø10/150

Slab thickness h_c (m)	Span L(m)																		
	1.00	1.25	1.50	1.75	2.00	2.25	2.50	2.75	3.00	3.25	3.50	3.75	4.00	4.25	4.50	4.75	5.00	5.25	5.50
0.13	26.24	20.51	16.80	14.12	11.02	8.40	6.47	5.03	3.94	3.08	2.40	1.85	1.40	1.03	0.71				
0.14	28.09	21.98	18.00	15.10	12.35	9.37	7.21	5.61	4.39	3.44	2.68	2.07	1.57	1.15	0.80	0.50			
0.15	29.91	23.45	19.05	16.05	13.53	10.33	7.96	6.19	4.85	3.80	2.96	2.29	1.73	1.27	0.89	0.56			
0.16	31.51	24.63	20.15	16.95	14.46	11.30	8.70	6.77	5.30	4.16	3.24	2.50	1.90	1.40	0.97	0.61			
0.17	33.28	25.96	21.25	17.70	15.20	12.25	9.45	7.35	5.76	4.51	3.52	2.72	2.06	1.52	1.06	0.67			
0.18	34.93	27.18	22.25	18.60	15.90	13.09	10.19	7.93	6.21	4.87	3.80	2.94	2.23	1.64	1.15	0.73			
0.19	36.25	28.57	23.15	19.45	16.59	14.05	10.95	8.51	6.67	5.23	4.08	3.16	2.40	1.76	1.23	0.78			
0.20	37.94	29.74	24.05	20.22	17.18	14.94	11.65	9.09	7.12	5.59	4.36	3.37	2.56	1.89	1.32	0.84			

Maximum values of the variable load (kN/m²) , $\psi_2=0.60$

	Steel sheeting thickness: t=1.25 mm Concrete: C20/25 Steel reinforcement: B500C
--	--

Reinforcement at the positions of hogging moments

h_c (m)	0.13	0.14	0.15	0.16	0.17	0.18	0.19	0.20
reinforcement	Ø8/150	Ø8/150	Ø8/150	Ø8/150	Ø10/200	Ø10/200	Ø10/150	Ø10/150

Slab thickness h_c (m)	Span L(m)																		
	1.00	1.25	1.50	1.75	2.00	2.25	2.50	2.75	3.00	3.25	3.50	3.75	4.00	4.25	4.50	4.75	5.00	5.25	5.50
0.13	28.46	22.36	18.29	15.39	13.20	10.85	8.45	6.65	5.30	4.25	3.40	2.72	2.15	1.70	1.31	0.98	0.70		
0.14	30.48	23.93	19.58	16.46	14.10	12.10	9.41	7.43	5.92	4.74	3.80	3.02	2.42	1.90	1.47	1.10	0.78		
0.15	32.45	25.45	20.67	17.45	14.95	12.95	10.32	8.20	6.53	5.23	4.20	3.36	2.67	2.10	1.62	1.21	0.87	0.57	
0.16	34.08	26.90	21.89	18.40	15.80	13.75	11.35	8.97	7.14	5.72	4.59	3.67	2.92	2.30	1.78	1.33	0.95	0.63	
0.17	35.84	28.25	23.08	19.25	16.50	14.45	12.30	9.67	7.76	6.21	4.99	4.00	3.18	2.50	1.94	1.45	1.04	0.69	
0.18	37.67	29.70	24.25	20.30	17.25	15.10	13.25	10.45	8.37	6.71	5.38	4.31	3.43	2.71	2.09	1.57	1.13	0.75	
0.19	39.36	30.95	25.30	21.20	18.00	15.65	13.80	11.25	8.99	7.20	5.78	4.63	3.69	2.91	2.25	1.69	1.22	0.81	
0.20	40.96	32.22	26.27	22.10	18.88	16.20	14.25	12.02	9.57	7.69	6.18	4.95	3.95	3.11	2.41	1.81	1.30	0.87	

Maximum values of the variable load (kN/m²) , $\psi_2=0.60$

No additional reinforcement	1ø6	1ø8	1ø10	1ø12	1ø14
-----------------------------	-----	-----	------	------	------

FIRE RESISTANCE: 90 minutes

	Steel sheeting thickness: t=0.75 mm Concrete: C20/25 Steel reinforcement: B500C
---	--

Reinforcement at the positions of hogging moments

h _c (m)	0.13	0.14	0.15	0.16	0.17	0.18	0.19	0.20
reinforcement	Ø8/200	Ø8/200	Ø8/150	Ø8/150	Ø10/200	Ø10/200	Ø10/150	Ø10/150

Slab thickness h _c (m)	Span L(m)																		
	1.00	1.25	1.50	1.75	2.00	2.25	2.50	2.75	3.00	3.25	3.50	3.75	4.00	4.25	4.50	4.75	5.00	5.25	5.50
0.13	27.24	21.39	17.48	14.60	12.60	9.95	7.67	5.99	4.71	3.71	2.92	2.28	1.76	1.32	0.96				
0.14	29.40	22.89	18.70	15.71	13.46	11.20	8.69	6.79	5.34	4.22	3.33	2.61	2.02	1.53	1.12	0.77			
0.15	30.80	24.14	19.84	16.68	14.28	12.36	9.71	7.59	5.98	4.73	3.73	2.93	2.27	1.73	1.27	0.89	0.56		
0.16	32.57	25.73	20.91	17.59	15.05	13.10	10.70	8.39	6.62	5.24	4.14	3.26	2.53	1.93	1.43	1.00	0.64		
0.17	34.26	27.05	21.96	18.39	15.77	13.75	11.65	9.16	7.33	5.85	4.67	3.72	2.93	2.29	1.74	1.28	0.88	0.54	
0.18	35.95	28.15	23.15	19.27	16.55	14.25	12.55	9.92	7.91	6.31	5.04	4.01	3.17	2.47	1.88	1.38	0.96	0.59	
0.19	37.60	29.52	24.15	20.04	17.25	14.82	13.10	10.67	8.49	6.78	5.41	4.31	3.41	2.66	2.03	1.49	1.03	0.64	
0.20	39.28	30.78	25.00	20.90	17.98	15.55	13.55	11.40	9.05	7.24	5.79	4.61	3.64	2.84	2.17	1.60	1.11	0.69	

Maximum values of the variable load (kN/m²) , $\psi_2=0.60$

	Steel sheeting thickness: t=0.80 mm Concrete: C20/25 Steel reinforcement: B500C
--	--

Reinforcement at the positions of hogging moments

h _c (m)	0.13	0.14	0.15	0.16	0.17	0.18	0.19	0.20
reinforcement	Ø8/200	Ø8/200	Ø8/150	Ø8/150	Ø10/200	Ø10/200	Ø10/150	Ø10/150

Slab thickness h _c (m)	Span L(m)																		
	1.00	1.25	1.50	1.75	2.00	2.25	2.50	2.75	3.00	3.25	3.50	3.75	4.00	4.25	4.50	4.75	5.00	5.25	5.50
0.13	24.06	18.97	15.40	11.67	8.54	6.38	4.83	3.68	2.81	2.12	1.58	1.14	0.77						
0.14	25.82	20.17	16.55	12.95	9.51	7.11	5.39	4.11	3.13	2.37	1.76	1.27	0.87	0.53					
0.15	27.55	21.55	17.55	14.30	10.49	7.84	5.94	4.53	3.45	2.61	1.94	1.40	0.96	0.59					
0.16	29.16	22.72	18.50	15.55	11.47	8.57	6.50	4.95	3.78	2.86	2.13	1.54	1.05	0.64					
0.17	30.64	23.86	19.45	16.30	12.45	9.31	7.05	5.38	4.10	3.10	2.31	1.67	1.14	0.70					
0.18	32.10	25.08	20.40	17.10	13.40	10.04	7.61	5.80	4.43	3.35	2.49	1.80	1.23	0.76					
0.19	33.63	26.28	21.35	17.80	14.35	10.77	8.16	6.23	4.75	3.60	2.68	1.93	1.32	0.82					
0.20	35.14	27.36	22.20	18.45	15.35	11.50	8.72	6.65	5.07	3.84	2.86	2.07	1.42	0.87					

Maximum values of the variable load (kN/m²) , $\psi_2=0.60$

No additional reinforcement	1Ø6	1Ø8	1Ø10	1Ø12	1Ø14
-----------------------------	-----	-----	------	------	------

FIRE RESISTANCE: 90 minutes

	Steel sheeting thickness: t=1.00 mm Concrete: C20/25 Steel reinforcement: B500C
---	--

Reinforcement at the positions of hogging moments

h _c (m)	0.13	0.14	0.15	0.16	0.17	0.18	0.19	0.20
reinforcement	Ø8/200	Ø8/200	Ø8/150	Ø8/150	Ø10/200	Ø10/200	Ø10/150	Ø10/150

Slab thickness h _c (m)	Span L(m)																		
	1.00	1.25	1.50	1.75	2.00	2.25	2.50	2.75	3.00	3.25	3.50	3.75	4.00	4.25	4.50	4.75	5.00	5.25	5.50
0.13	26.24	20.51	16.80	14.12	11.02	8.40	6.47	5.03	3.94	3.08	2.40	1.85	1.40	1.03	0.71				
0.14	28.09	21.98	18.00	15.10	12.35	9.37	7.21	5.61	4.39	3.44	2.68	2.07	1.57	1.15	0.80	0.50			
0.15	29.91	23.45	19.05	16.05	13.53	10.33	7.96	6.19	4.85	3.80	2.96	2.29	1.73	1.27	0.89	0.56			
0.16	31.51	24.63	20.15	16.95	14.46	11.30	8.70	6.77	5.30	4.16	3.24	2.50	1.90	1.40	0.97	0.61			
0.17	33.28	25.96	21.25	17.70	15.20	12.25	9.45	7.35	5.76	4.51	3.52	2.72	2.06	1.52	1.06	0.67			
0.18	34.93	27.18	22.25	18.60	15.90	13.09	10.19	7.93	6.21	4.87	3.80	2.94	2.23	1.64	1.15	0.73			
0.19	36.25	28.57	23.15	19.45	16.59	14.05	10.95	8.51	6.67	5.23	4.08	3.16	2.40	1.76	1.23	0.78			
0.20	37.94	29.74	24.05	20.22	17.18	14.94	11.65	9.09	7.12	5.59	4.36	3.37	2.56	1.89	1.32	0.84			

Maximum values of the variable load (kN/m²) , ψ₂=0.60

	Steel sheeting thickness: t=1.25 mm Concrete: C20/25 Steel reinforcement: B500C
---	--

Reinforcement at the positions of hogging moments

h _c (m)	0.13	0.14	0.15	0.16	0.17	0.18	0.19	0.20
reinforcement	Ø8/150	Ø8/150	Ø8/150	Ø8/150	Ø10/200	Ø10/200	Ø10/150	Ø10/150

Slab thickness h _c (m)	Span L(m)																		
	1.00	1.25	1.50	1.75	2.00	2.25	2.50	2.75	3.00	3.25	3.50	3.75	4.00	4.25	4.50	4.75	5.00	5.25	5.50
0.13	28.46	22.36	18.29	15.39	13.20	10.85	8.45	6.65	5.30	4.25	3.40	2.72	2.15	1.70	1.31	0.98	0.70		
0.14	30.48	23.93	19.58	16.46	14.10	12.10	9.41	7.43	5.92	4.74	3.80	3.02	2.42	1.90	1.47	1.10	0.78		
0.15	32.45	25.45	20.67	17.45	14.95	12.95	10.32	8.20	6.53	5.23	4.20	3.36	2.67	2.10	1.62	1.21	0.87	0.57	
0.16	34.08	26.90	21.89	18.40	15.80	13.75	11.35	8.97	7.14	5.72	4.59	3.67	2.92	2.30	1.78	1.33	0.95	0.63	
0.17	35.84	28.25	23.08	19.25	16.50	14.45	12.30	9.67	7.76	6.21	4.99	4.00	3.18	2.50	1.94	1.45	1.04	0.69	
0.18	37.67	29.70	24.25	20.30	17.25	15.10	13.25	10.45	8.37	6.71	5.38	4.31	3.43	2.71	2.09	1.57	1.13	0.75	
0.19	39.36	30.95	25.30	21.20	18.00	15.65	13.80	11.25	8.99	7.20	5.78	4.63	3.69	2.91	2.25	1.69	1.22	0.81	
0.20	40.96	32.22	26.27	22.10	18.88	16.20	14.25	12.02	9.57	7.69	6.18	4.95	3.95	3.11	2.41	1.81	1.30	0.87	

Maximum values of the variable load (kN/m²) , ψ₂=0.60

No additional reinforcement	1ø6	1ø8	1ø10	1ø12	1ø14
-----------------------------	-----	-----	------	------	------

FIRE RESISTANCE: 120 minutes

	Steel sheeting thickness: t=0.75 mm Concrete: C20/25 Steel reinforcement: B500C
---	--

Reinforcement at the positions of hogging moments

h _c (m)	0.13	0.14	0.15	0.16	0.17	0.18	0.19	0.20
reinforcement	Ø8/200	Ø8/200	Ø8/150	Ø8/150	Ø10/200	Ø10/200	Ø10/150	Ø10/150

Slab thickness h _c (m)	Span L(m)																		
	1.00	1.25	1.50	1.75	2.00	2.25	2.50	2.75	3.00	3.25	3.50	3.75	4.00	4.25	4.50	4.75	5.00	5.25	5.50
0.13	27.24	21.39	17.48	14.60	12.60	9.95	7.67	5.99	4.71	3.71	2.92	2.28	1.76	1.32	0.96				
0.14	29.40	22.89	18.70	15.71	13.46	11.20	8.69	6.79	5.34	4.22	3.33	2.61	2.02	1.53	1.12	0.69			
0.15	30.80	24.14	19.84	16.68	14.28	12.36	9.71	7.59	5.98	4.73	3.73	2.93	2.27	1.73	1.27	0.74	0.23		
0.16	32.57	25.73	20.91	17.59	15.05	13.10	10.70	8.39	6.62	5.24	4.14	3.26	2.53	1.93	1.43	0.78	0.22		
0.17	34.26	27.05	21.96	18.39	15.77	13.75	11.65	9.16	7.33	5.85	4.67	3.72	2.93	2.29	1.52	0.82	0.22		
0.18	35.95	28.15	23.15	19.27	16.55	14.25	12.55	9.92	7.91	6.31	5.04	4.01	3.17	2.47	1.62	0.86	0.22		
0.19	37.60	29.52	24.15	20.04	17.25	14.82	13.10	10.67	8.49	6.78	5.41	4.31	3.41	2.66	1.71	0.90	0.21		
0.20	39.28	30.78	25.00	20.90	17.98	15.55	13.55	11.40	9.05	7.24	5.79	4.61	3.64	2.82	1.81	0.95	0.21		

Maximum values of the variable load (kN/m²), $\psi_2=0.60$

	Steel sheeting thickness: t=0.80 mm Concrete: C20/25 Steel reinforcement: B500C
--	--

Reinforcement at the positions of hogging moments

h _c (m)	0.13	0.14	0.15	0.16	0.17	0.18	0.19	0.20
reinforcement	Ø8/200	Ø8/200	Ø8/150	Ø8/150	Ø10/200	Ø10/200	Ø10/150	Ø10/150

Slab thickness h _c (m)	Span L(m)																		
	1.00	1.25	1.50	1.75	2.00	2.25	2.50	2.75	3.00	3.25	3.50	3.75	4.00	4.25	4.50	4.75	5.00	5.25	5.50
0.13	24.06	18.97	15.40	11.67	8.54	6.38	4.83	3.68	2.81	2.12	1.58	1.14	0.77						
0.14	25.82	20.17	16.55	12.95	9.51	7.11	5.39	4.11	3.13	2.37	1.76	1.27	0.87	0.53					
0.15	27.55	21.55	17.55	14.30	10.49	7.84	5.94	4.53	3.45	2.61	1.94	1.40	0.96	0.59					
0.16	29.16	22.72	18.50	15.55	11.47	8.57	6.50	4.95	3.78	2.86	2.13	1.54	1.05	0.64					
0.17	30.64	23.86	19.45	16.30	12.45	9.31	7.05	5.38	4.10	3.10	2.31	1.67	1.14	0.70					
0.18	32.10	25.08	20.40	17.10	13.40	10.04	7.61	5.80	4.43	3.35	2.49	1.80	1.23	0.76					
0.19	33.63	26.28	21.35	17.80	14.35	10.77	8.16	6.23	4.75	3.60	2.68	1.93	1.32	0.82					
0.20	35.14	27.36	22.20	18.45	15.35	11.50	8.72	6.65	5.07	3.84	2.86	2.07	1.42	0.87					

Maximum values of the variable load (kN/m²), $\psi_2=0.60$

No additional reinforcement	1ø6	1ø8	1ø10	1ø12	1ø14
-----------------------------	-----	-----	------	------	------

FIRE RESISTANCE: 120 minutes

	Steel sheeting thickness: t=1.00 mm Concrete: C20/25 Steel reinforcement: B500C
---	--

Reinforcement at the positions of hogging moments

h _c (m)	0.13	0.14	0.15	0.16	0.17	0.18	0.19	0.20
reinforcement	Ø8/200	Ø8/200	Ø8/150	Ø8/150	Ø10/200	Ø10/200	Ø10/150	Ø10/150

Slab thickness	Span L(m)																			
	h _c (m)	1.00	1.25	1.50	1.75	2.00	2.25	2.50	2.75	3.00	3.25	3.50	3.75	4.00	4.25	4.50	4.75	5.00	5.25	5.50
0.13	26.24	20.51	16.80	14.12	11.02	8.40	6.47	5.03	3.94	3.08	2.40	1.85	1.40	1.03	0.71					
0.14	28.09	21.98	18.00	15.10	12.35	9.37	7.21	5.61	4.39	3.44	2.68	2.07	1.57	1.15	0.80	0.50				
0.15	29.91	23.45	19.05	16.05	13.53	10.33	7.96	6.19	4.85	3.80	2.96	2.29	1.73	1.27	0.89	0.56				
0.16	31.51	24.63	20.15	16.95	14.46	11.30	8.70	6.77	5.30	4.16	3.24	2.50	1.90	1.40	0.97	0.61				
0.17	33.28	25.96	21.25	17.70	15.20	12.25	9.45	7.35	5.76	4.51	3.52	2.72	2.06	1.52	1.06	0.67				
0.18	34.93	27.18	22.25	18.60	15.90	13.09	10.19	7.93	6.21	4.87	3.80	2.94	2.23	1.64	1.15	0.73				
0.19	36.25	28.57	23.15	19.45	16.59	14.05	10.95	8.51	6.67	5.23	4.08	3.16	2.40	1.76	1.23	0.78				
0.20	37.94	29.74	24.05	20.22	17.18	14.94	11.65	9.09	7.12	5.59	4.36	3.37	2.56	1.89	1.32	0.84				

Maximum values of the variable load (kN/m²), $\psi_2=0.60$

	Steel sheeting thickness: t=1.25 mm Concrete: C20/25 Steel reinforcement: B500C
--	--

Reinforcement at the positions of hogging moments

h _c (m)	0.13	0.14	0.15	0.16	0.17	0.18	0.19	0.20
reinforcement	Ø8/150	Ø8/150	Ø8/150	Ø8/150	Ø10/200	Ø10/200	Ø10/150	Ø10/150

Slab thickness	Span L(m)																			
	h _c (m)	1.00	1.25	1.50	1.75	2.00	2.25	2.50	2.75	3.00	3.25	3.50	3.75	4.00	4.25	4.50	4.75	5.00	5.25	5.50
0.13	28.46	22.36	18.29	15.39	13.20	10.85	8.45	6.65	5.30	4.25	3.40	2.72	2.15	1.70	1.31	0.98	0.70			
0.14	30.48	23.93	19.58	16.46	14.10	12.10	9.41	7.43	5.92	4.74	3.80	3.02	2.42	1.90	1.47	1.10	0.78			
0.15	32.45	25.45	20.67	17.45	14.95	12.95	10.32	8.20	6.53	5.23	4.20	3.36	2.67	2.10	1.62	1.21	0.87	0.40		
0.16	34.08	26.90	21.89	18.40	15.80	13.75	11.35	8.97	7.14	5.72	4.59	3.67	2.92	2.30	1.78	1.33	0.95	0.43		
0.17	35.84	28.25	23.08	19.25	16.50	14.45	12.30	9.67	7.76	6.21	4.99	4.00	3.18	2.50	1.94	1.45	1.04	0.46		
0.18	37.67	29.70	24.25	20.30	17.25	15.10	13.25	10.45	8.37	6.71	5.38	4.31	3.43	2.71	2.09	1.57	1.13	0.49		
0.19	39.36	30.95	25.30	21.20	18.00	15.65	13.80	11.25	8.99	7.20	5.78	4.63	3.69	2.91	2.25	1.69	1.21	0.52		
0.20	40.96	32.22	26.27	22.10	18.88	16.20	14.25	12.02	9.57	7.69	6.18	4.95	3.95	3.11	2.41	1.81	1.28	0.54		

Maximum values of the variable load (kN/m²), $\psi_2=0.60$

No additional reinforcement	1ø6	1ø8	1ø10	1ø12	1ø14
-----------------------------	-----	-----	------	------	------

DESIGN TABLES FOR LIGHT FLOORS MADE OF SYMDECK73 STEEL SHEETING (COLD FORMED THIN SHEETING SECTION)

The ultimate loads for light floors made of SYMDECK73 steel sheeting are given in the following (i.e. without the consideration of the composite action). The tables can be used for the design of light floors (e.g steel sheeting + laminate wood + coverage) or in the case of covering the steel sheeting with light weight concrete where the composite action is neglected.

The floor loads are divided in two categories: permanent load G and variable load Q . The design for the two states considered is described below:

Serviceability limit state – SLS

For the serviceability limit state, the ultimate load is given for two displacement limits, $L/200$ και $L/300$ where L is the span length. This ultimate load refers to the load combination $G+Q$ (safety factors equal to 1.00). These loads are presented in the tables as

$$q_{Rd-SLS-L/200} \text{ and } q_{Rd-SLS-L/300} .$$

Ultimate limit state – ULS

In the ultimate limit state, the ultimate load is calculated taking into account the bending moment resistance of the most critical cross-section. The calculated ultimate loads correspond to the load combination $1.35G+1.50Q$ and denoted in the tables as q_{Rd-ULS} .

USE OF TABLES

Depending on the rate between permanent and variable loads, the critical check may correspond either to the serviceability or to the ultimate limit state.

Example

Consider a floor in which the following loads are applied:

- Permanent load $G=1.0 \text{ kN/m}^2$
- Variable load $Q=5.0 \text{ kN/m}^2$

The design of the floor is required (steel thickness, span lengths) for three equal spans continuous beam structural system. The serviceability limit state check should be performed with an acceptable displacement equal to $L/300$.

1. Calculation of design load for the serviceability limit state.

$$q_{Sd-SLS} = G + Q = 1.0 + 5.0 = 6.0 \text{ kN/m}^2$$

2. Calculation of design load for the ultimate limit state.

$$q_{Sd-ULS} = 1.35G + 1.5Q = 1.35 \times 1.0 + 1.5 \times 5.0 = 8.85 \text{ kN/m}^2$$

3. From the design tables for a continuous beam of three equal spans, the following combinations are obtained that satisfy both the SLS check ($q_{Sd-SLS} < q_{Rd-SLS-L/300}$) and the ULS check ($q_{Sd-ULS} < q_{Rd-ULS}$):

- t=0.75mm, L=2.25m
- t=0.80mm, L=2.25m
- t=1.00mm, L=2.75m
- t=1.25mm, L=3.00m

SYMDECK73 – DESIGN TABLES (FOR COLD FORMED STEEL THIN SHEETING)



t=0.75mm

<i>L (m)</i>	1.50	1.75	2.00	2.25	2.50	2.75	3.00	3.25	3.50	3.75	4.00	4.25	4.50	4.75	5.00	5.25	5.50	5.75	6.00
<i>q_{Rd-SLS-L/200}</i>	26.28	16.55	11.09	7.79	5.68	4.27	3.29	2.58	2.07	1.68	1.39	1.16	0.97	0.83	0.71	0.61	0.53	0.47	0.41
<i>q_{Rd-SLS-L/300}</i>	17.52	11.03	7.39	5.19	3.78	2.84	2.19	1.72	1.38	1.12	0.92	0.77	0.65	0.55	0.47	0.41	0.36	0.31	0.27
<i>q_{Rd-ULS}</i>	22.97	16.88	12.92	10.21	8.27	6.83	5.74	4.89	4.22	3.68	3.23	2.86	2.55	2.29	2.07	1.88	1.71	1.56	1.44

Ultimate loads in kN/m² for the ultimate and serviceability limit states.



t=0.80mm

<i>L (m)</i>	1.50	1.75	2.00	2.25	2.50	2.75	3.00	3.25	3.50	3.75	4.00	4.25	4.50	4.75	5.00	5.25	5.50	5.75	6.00
<i>q_{Rd-SLS-L/200}</i>	28.03	17.65	11.83	8.31	6.06	4.55	3.50	2.76	2.21	1.79	1.48	1.23	1.04	0.88	0.76	0.65	0.57	0.50	0.44
<i>q_{Rd-SLS-L/300}</i>	18.69	11.77	7.88	5.54	4.04	3.03	2.34	1.84	1.47	1.20	0.99	0.82	0.69	0.59	0.50	0.44	0.38	0.33	0.29
<i>q_{Rd-ULS}</i>	24.57	18.05	13.82	10.92	8.84	7.31	6.14	5.23	4.51	3.93	3.46	3.06	2.73	2.45	2.21	2.00	1.83	1.67	1.54

Ultimate loads in kN/m² for the ultimate and serviceability limit states.



t=1.00mm

<i>L (m)</i>	1.50	1.75	2.00	2.25	2.50	2.75	3.00	3.25	3.50	3.75	4.00	4.25	4.50	4.75	5.00	5.25	5.50	5.75	6.00
<i>q_{Rd-SLS-L/200}</i>	35.18	22.15	14.84	10.42	7.60	5.71	4.40	3.46	2.77	2.25	1.86	1.55	1.30	1.11	0.95	0.82	0.71	0.62	0.55
<i>q_{Rd-SLS-L/300}</i>	23.45	14.77	9.89	6.95	5.07	3.81	2.93	2.31	1.85	1.50	1.24	1.03	0.87	0.74	0.63	0.55	0.48	0.42	0.37
<i>q_{Rd-ULS}</i>	30.86	22.67	17.36	13.72	11.11	9.18	7.72	6.57	5.67	4.94	4.34	3.84	3.43	3.08	2.78	2.52	2.30	2.10	1.93

Ultimate loads in kN/m² for the ultimate and serviceability limit states.



t=1.25mm

<i>L (m)</i>	1.50	1.75	2.00	2.25	2.50	2.75	3.00	3.25	3.50	3.75	4.00	4.25	4.50	4.75	5.00	5.25	5.50	5.75	6.00
<i>q_{Rd-SLS-L/200}</i>	44.07	27.75	18.59	13.06	9.52	7.15	5.51	4.33	3.47	2.82	2.32	1.94	1.63	1.39	1.19	1.03	0.89	0.78	0.69
<i>q_{Rd-SLS-L/300}</i>	29.38	18.50	12.39	8.70	6.35	4.77	3.67	2.89	2.31	1.88	1.55	1.29	1.09	0.93	0.79	0.69	0.60	0.52	0.46
<i>q_{Rd-ULS}</i>	38.72	28.45	21.78	17.21	13.94	11.52	9.68	8.25	7.11	6.20	5.44	4.82	4.30	3.86	3.48	3.16	2.88	2.64	2.42

Ultimate loads in kN/m² for the ultimate and serviceability limit states.

SYMDECK73 – DESIGN TABLES (FOR COLD FORMED STEEL THIN SHEETING)



																	<i>t=0.75mm</i>			
<i>L (m)</i>	1.50	1.75	2.00	2.25	2.50	2.75	3.00	3.25	3.50	3.75	4.00	4.25	4.50	4.75	5.00	5.25	5.50	5.75	6.00	
<i>q_{Rd-SLS-L/200}</i>	63.03	39.77	26.67	18.72	13.65	10.26	7.89	6.20	4.97	4.03	3.33	2.78	2.34	2.00	1.70	1.47	1.28	1.12	0.99	
<i>q_{Rd-SLS-L/300}</i>	42.02	26.52	17.78	12.48	9.10	6.84	5.26	4.13	3.31	2.69	2.22	1.85	1.56	1.33	1.13	0.98	0.85	0.75	0.66	
<i>q_{Rd-ULS}</i>	17.44	12.86	9.88	7.84	6.36	5.28	4.44	3.79	3.27	2.85	2.51	2.22	1.99	1.78	1.61	1.46	1.33	1.22	1.12	

Ultimate loads in kN/m² for the ultimate and serviceability limit states.



																	<i>t=0.80mm</i>			
<i>L (m)</i>	1.50	1.75	2.00	2.25	2.50	2.75	3.00	3.25	3.50	3.75	4.00	4.25	4.50	4.75	5.00	5.25	5.50	5.75	6.00	
<i>q_{Rd-SLS-L/200}</i>	67.57	42.48	28.41	19.98	14.55	10.91	8.43	6.63	5.30	4.31	3.55	2.96	2.50	2.12	1.82	1.57	1.37	1.20	1.05	
<i>q_{Rd-SLS-L/300}</i>	45.05	28.32	18.94	13.32	9.70	7.28	5.62	4.42	3.54	2.87	2.37	1.98	1.66	1.41	1.22	1.05	0.91	0.80	0.70	
<i>q_{Rd-ULS}</i>	19.05	14.05	10.80	8.57	6.96	5.77	4.85	4.14	3.57	3.12	2.74	2.43	2.17	1.95	1.76	1.60	1.45	1.33	1.22	

Ultimate loads in kN/m² for the ultimate and serviceability limit states.



																	<i>t=1.00mm</i>			
<i>L (m)</i>	1.50	1.75	2.00	2.25	2.50	2.75	3.00	3.25	3.50	3.75	4.00	4.25	4.50	4.75	5.00	5.25	5.50	5.75	6.00	
<i>q_{Rd-SLS-L/200}</i>	84.55	53.35	35.71	25.06	18.27	13.75	10.56	8.33	6.65	5.42	4.46	3.72	3.13	2.66	2.27	1.97	1.72	1.50	1.32	
<i>q_{Rd-SLS-L/300}</i>	56.37	35.57	23.81	16.70	12.18	9.17	7.04	5.56	4.44	3.61	2.98	2.48	2.09	1.78	1.52	1.32	1.15	1.00	0.88	
<i>q_{Rd-ULS}</i>	25.91	19.11	14.69	11.65	9.47	7.84	6.60	5.64	4.87	4.24	3.73	3.31	2.95	2.65	2.40	2.17	1.98	1.81	1.66	

Ultimate loads in kN/m² for the ultimate and serviceability limit states.



																	<i>t=1.25mm</i>			
<i>L (m)</i>	1.50	1.75	2.00	2.25	2.50	2.75	3.00	3.25	3.50	3.75	4.00	4.25	4.50	4.75	5.00	5.25	5.50	5.75	6.00	
<i>q_{Rd-SLS-L/200}</i>	105.9	66.79	44.64	31.42	22.89	17.19	13.27	10.42	8.33	6.77	5.59	4.66	3.93	3.34	2.86	2.48	2.15	1.88	1.66	
<i>q_{Rd-SLS-L/300}</i>	70.62	44.53	29.76	20.95	15.26	11.46	8.85	6.94	5.56	4.51	3.72	3.11	2.62	2.22	1.91	1.65	1.43	1.25	1.10	
<i>q_{Rd-ULS}</i>	35.09	25.89	19.90	15.79	12.83	10.63	8.95	7.64	6.60	5.75	5.06	4.48	4.00	3.60	3.25	2.94	2.68	2.45	2.25	

Ultimate loads in kN/m² for the ultimate and serviceability limit states.

SYMDECK73 – DESIGN TABLES (FOR COLD FORMED STEEL THIN SHEETING)



																		<i>t=0.75mm</i>	
<i>L (m)</i>	1.50	1.75	2.00	2.25	2.50	2.75	3.00	3.25	3.50	3.75	4.00	4.25	4.50	4.75	5.00	5.25	5.50	5.75	6.00
<i>q_{Rd-SLS-L/200}</i>	49.67	31.36	20.96	14.73	10.78	8.09	6.22	4.90	3.92	3.18	2.62	2.19	1.84	1.56	1.34	1.16	1.01	0.88	0.78
<i>q_{Rd-SLS-L/300}</i>	33.11	20.91	13.98	9.82	7.18	5.39	4.15	3.26	2.61	2.12	1.75	1.46	1.23	1.04	0.90	0.77	0.67	0.59	0.52
<i>q_{Rd-ULS}</i>	21.80	16.07	12.35	9.80	7.95	6.60	5.55	4.73	4.08	3.56	3.14	2.78	2.48	2.23	2.01	1.82	1.66	1.52	1.40

Ultimate loads in kN/m² for the ultimate and serviceability limit states.



																		<i>t=0.80mm</i>	
<i>L (m)</i>	1.50	1.75	2.00	2.25	2.50	2.75	3.00	3.25	3.50	3.75	4.00	4.25	4.50	4.75	5.00	5.25	5.50	5.75	6.00
<i>q_{Rd-SLS-L/200}</i>	53.19	33.40	22.37	15.71	11.47	8.59	6.64	5.21	4.18	3.40	2.80	2.33	1.96	1.67	1.43	1.24	1.07	0.94	0.83
<i>q_{Rd-SLS-L/300}</i>	35.46	22.26	14.91	10.47	7.65	5.73	4.43	3.47	2.78	2.26	1.87	1.55	1.30	1.12	0.95	0.83	0.72	0.63	0.55
<i>q_{Rd-ULS}</i>	23.82	17.56	13.50	10.71	8.70	7.21	6.07	5.18	4.47	3.90	3.43	3.04	2.71	2.44	2.20	2.00	1.82	1.66	1.53

Ultimate loads in kN/m² for the ultimate and serviceability limit states.



																		<i>t=1.00mm</i>	
<i>L (m)</i>	1.50	1.75	2.00	2.25	2.50	2.75	3.00	3.25	3.50	3.75	4.00	4.25	4.50	4.75	5.00	5.25	5.50	5.75	6.00
<i>q_{Rd-SLS-L/200}</i>	66.37	41.87	28.09	19.70	14.37	10.83	8.33	6.55	5.24	4.26	3.51	2.93	2.46	2.10	1.80	1.55	1.35	1.18	1.04
<i>q_{Rd-SLS-L/300}</i>	44.25	27.91	18.73	13.13	9.58	7.22	5.56	4.37	3.49	2.84	2.34	1.95	1.64	1.40	1.20	1.04	0.90	0.79	0.69
<i>q_{Rd-ULS}</i>	32.40	23.89	18.36	14.57	11.84	9.81	8.25	7.05	6.08	5.30	4.67	4.14	3.69	3.32	3.00	2.71	2.47	2.26	2.08

Ultimate loads in kN/m² for the ultimate and serviceability limit states.



																		<i>t=1.25mm</i>	
<i>L (m)</i>	1.50	1.75	2.00	2.25	2.50	2.75	3.00	3.25	3.50	3.75	4.00	4.25	4.50	4.75	5.00	5.25	5.50	5.75	6.00
<i>q_{Rd-SLS-L/200}</i>	83.33	52.40	35.21	24.67	18.01	13.48	10.42	8.21	6.55	5.34	4.40	3.66	3.07	2.62	2.25	1.94	1.69	1.48	1.30
<i>q_{Rd-SLS-L/300}</i>	55.56	34.93	23.47	16.45	12.01	8.99	6.94	5.47	4.37	3.56	2.93	2.44	2.06	1.75	1.50	1.30	1.13	0.99	0.87
<i>q_{Rd-ULS}</i>	43.87	32.35	24.87	19.74	16.04	13.29	11.18	9.55	8.24	7.19	6.33	5.61	5.00	4.49	4.06	3.68	3.35	3.07	2.82

Ultimate loads in kN/m² for the ultimate and serviceability limit states.